

JEE Main 2020 Paper

Date of Exam: **8th January (Shift II)**

Time: **2:30 pm – 5:30 pm**

Subject: **Physics**

1. Find magnetic field at O. Where R is the radius of the loop

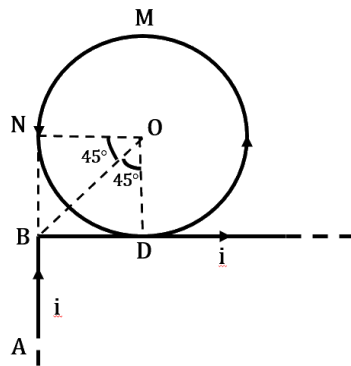

a. $\frac{\mu_0 i}{2\pi R} \left[\frac{-1}{\sqrt{2}} + \pi \right]$

b. $\frac{\mu_0 i}{2\pi R} [\pi - 1]$

c. $\frac{\mu_0 i}{2R}$

d. $\frac{\mu_0 i}{2\pi R} \left[\frac{1}{\sqrt{2}} + \pi \right]$

Solution: (d)

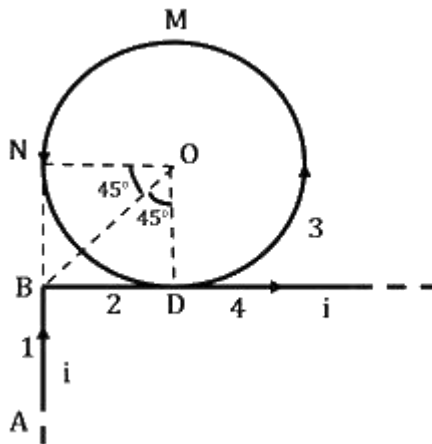

To get magnetic field at O, we need to find magnetic field due to each current carrying part 1, 2, 3 and 4 individually.

Let's take total magnetic field as B_T , then

$$\vec{B}_T = \vec{B}_1 + \vec{B}_2 + \vec{B}_3 + \vec{B}_4$$

Since 2 and 4 are parts of same wire, hence

$$\begin{aligned}\vec{B}_T &= \frac{\mu_0 i}{4\pi R} (\sin 90^\circ - \sin 45^\circ)(-\hat{k}) + \frac{\mu_0 i}{2R} \hat{k} + \frac{\mu_0 i}{4\pi R} (\sin 90^\circ + \sin 45^\circ)\hat{k} \\ &= \frac{-\mu_0 i}{4\pi R} \left[1 - \frac{1}{\sqrt{2}}\right] + \frac{\mu_0 i}{2R} + \frac{\mu_0 i}{4\pi R} \left[1 + \frac{1}{\sqrt{2}}\right] \hat{k}\end{aligned}$$

$$\vec{B}_T = \frac{\mu_0 i}{4\pi R} [\sqrt{2} + 2\pi] \hat{k}$$

$$\vec{B}_T = \frac{\mu_0 i}{2\pi R} \left[\frac{1}{\sqrt{2}} + \pi\right] \hat{k}$$

\hat{k} denotes that direction of magnetic field is in the plane coming out of the plane of current.

2. Position of particle as a function of time is given as $\vec{r} = \cos \omega t \hat{i} + \sin \omega t \hat{j}$, where ω is constant. Choose correct statement about \vec{r} , \vec{v} and \vec{a} where \vec{v} and \vec{a} are the velocity and acceleration of the particle at time t .
- \vec{v} and \vec{a} are perpendicular to \vec{r}
 - \vec{v} is parallel to \vec{r} and \vec{a} parallel to \vec{r}
 - \vec{v} is perpendicular to \vec{r} and \vec{a} is away from the origin
 - \vec{v} is perpendicular to \vec{r} and \vec{a} is towards the origin

Solution:(d)

$$\vec{r} = \cos \omega t \hat{i} + \sin \omega t \hat{j}$$

$$\vec{v} = \frac{d\vec{r}}{dt} = \omega[-\sin \omega t \hat{i} + \cos \omega t \hat{j}]$$

$$\vec{a} = \frac{d\vec{v}}{dt} = -\omega^2[\cos \omega t \hat{i} + \sin \omega t \hat{j}]$$

$$\vec{a} = -\omega^2 \vec{r}$$

Since there is negative sign in acceleration, this means that acceleration is in opposite direction of \vec{r}

For velocity direction we can take dot product of \vec{v} and \vec{r} .

$$\begin{aligned}\vec{v} \cdot \vec{r} &= \omega(-\sin \omega t \hat{i} + \cos \omega t \hat{j}) \cdot (\cos \omega t \hat{i} + \sin \omega t \hat{j}) \\ &= \omega[-\sin \omega t \cos \omega t + \cos \omega t \sin \omega t] = 0\end{aligned}$$

which implies that \vec{v} is perpendicular to \vec{r} .

3. Two uniformly charged solid spheres are such that E_1 is electric field at surface of 1st sphere due to itself. E_2 is electric field at surface of 2nd sphere due to itself. r_1, r_2 are radius of 1st and 2nd sphere respectively. If $\frac{E_1}{E_2} = \frac{r_1}{r_2}$ then ratio of potential at the surface of spheres 1st and 2nd due to their self charges is :
- a. $\frac{r_1}{r_2}$ b. $\left(\frac{r_1}{r_2}\right)^2$
 c. $\frac{r_2}{r_1}$ d. $\left(\frac{r_2}{r_1}\right)^2$

Solution: (b)

$$\begin{aligned}\frac{E_1}{E_2} &= \frac{r_1}{r_2} \\ \frac{V_1}{V_2} &= \frac{E_1 r_1}{E_2 r_2} = \frac{r_1}{r_2} \times \frac{r_1}{r_2} = \left(\frac{r_1}{r_2}\right)^2\end{aligned}$$

4. Velocity of a wave in a wire is v when tension in it is $2.06 \times 10^4 \text{ N}$. Find value of tension in wire when velocity of wave become $\frac{v}{2}$.
- a. $5.15 \times 10^2 \text{ N}$ b. $9.12 \times 10^4 \text{ N}$
 c. $9 \times 10^4 \text{ N}$ d. $5.15 \times 10^3 \text{ N}$

Solution:(d)

$$\begin{aligned}V &\propto \sqrt{T} \\ \frac{V_1}{V_2} &= \sqrt{\frac{T_1}{T_2}} \\ \Rightarrow \frac{2V}{V} &= \sqrt{\frac{2.06 \times 10^4}{T}} \\ \Rightarrow T &= \frac{2.06 \times 10^4}{4} \text{ N} \\ &= 5.15 \times 10^3 \text{ N}\end{aligned}$$

5. There are two identical particles A and B . One is projected vertically upward with speed $\sqrt{2gh}$ from ground and other is dropped from height h along the same vertical line. Collision between them is perfectly inelastic. Find time taken by them to reach the ground after collision in terms of $\sqrt{\frac{h}{g}}$ is.

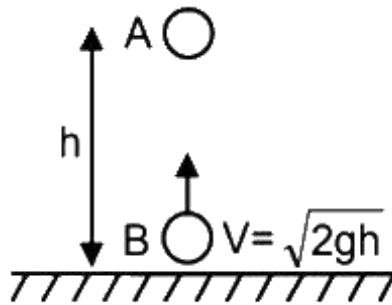

a. $\sqrt{\frac{3}{2}}$
c. $\sqrt{3}$

b. $\sqrt{\frac{1}{2}}$
d. $\sqrt{\frac{1}{5}}$

Solution:(a)

Time taken for the collision $t_1 = \frac{h}{\sqrt{2gh}}$

After t_1

$$V_A = 0 - gt_1 = -\frac{\sqrt{gh}}{2}$$

And $V_B = \sqrt{2gh} - gt_1 = \sqrt{gh} \left[\sqrt{2} - \frac{1}{\sqrt{2}} \right]$

At the time of collision

$$\vec{P}_i = \vec{P}_f$$

$$\Rightarrow m \vec{V}_A + m \vec{V}_B = 2 m \vec{V}_f$$

$$\Rightarrow -\sqrt{\frac{gh}{2}} + \sqrt{gh} \left[\sqrt{2} - \frac{1}{\sqrt{2}} \right] = 2 \vec{V}_f$$

$$V_f = 0$$

And height from the ground = $h - \frac{1}{2} g t_1^2 = h - \frac{h}{4} = \frac{3h}{4}$.

So, time taken to reach ground after collision = $\sqrt{2 \times \frac{(3h)}{g}} = \sqrt{\frac{3h}{2g}}$

6. A Carnot engine, having an efficiency of $\eta = 1/10$ as heat engine, is used as a refrigerator. If the work done on the system is 10 J, the amount of energy absorbed from the reservoir at lower temperature is
- a. 99 J b. 90 J
c. 1 J d. 100 J

Solution:(b)

For Carnot engine using as refrigerator

Work done on engine is given by

$$W = Q_1 - Q_2 \dots (1)$$

where Q_1 is heat rejected to the reservoir at higher temperature and Q_2 is the heat absorbed from the reservoir at lower temperature.

It is given $\eta = 1/10$

$$\eta = 1 - \frac{Q_2}{Q_1}$$

$$\Rightarrow \frac{Q_2}{Q_1} = \frac{9}{10} \dots (2)$$

We are given, $W = 10$ J

Therefore, from equations (1) and (2),

$$Q_2 = \frac{10}{\frac{10}{9} - 1}$$

$$\Rightarrow Q_2 = 90$$
 J

7. Two liquid columns of same height 5 m and densities ρ and 2ρ are filled in a container of uniform cross-sectional area. Then ratio of force exerted by the liquid on upper half of the wall to lower half of the wall is

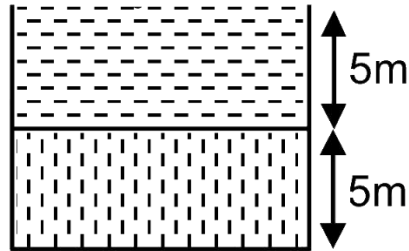

a. $\frac{2}{3}$
c. $\frac{1}{4}$

b. $\frac{1}{2}$
d. $\frac{2}{5}$

Solution:(c)

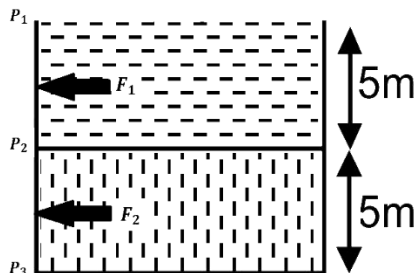

The net force exerted on the wall by one type of liquid will be average value of pressure due to that liquid multiplied by the area of the wall.

Here, since the pressure due a liquid of uniform density varies linearly with depth, its average will be just the mean value of pressure at the top and pressure at the bottom.

So,

$$P_1 = 0$$

$$P_2 = \rho g \times 5$$

$$P_3 = 5\rho g + 2\rho g \times 5$$

$$F_1 = \left(\frac{P_1 + P_2}{2}\right)A$$

$$F_2 = \left(\frac{P_2 + P_3}{2}\right)A$$

So,

$$\frac{F_1}{F_2} = \frac{1}{4}$$

8. A uniform solid sphere of radius R has a cavity of radius 1 m cut from it. If the center of mass of the system lies at the periphery of the cavity then

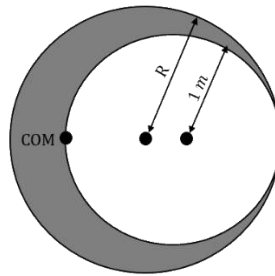

a. $(R^2 + R + 1)(2 - R) = 1$

b. $(R^2 - R - 1)(2 - R) = 1$

c. $(R^2 - R + 1)(2 - R) = 1$

d. $(R^2 + R - 1)(2 - R) = 1$

Solution (a)

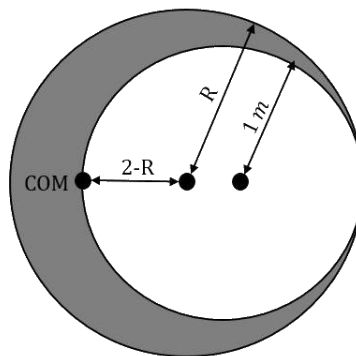

Let M be the mass of the sphere and M' be the mass of the cavity.

Mass of the remaining part of the sphere = $M - M'$

Mass moments of the cavity and the remaining part of sphere about the original CoM should add up to zero.

$$(M - M')(2 - R) - M'(R - 1) = 0$$

(Mass of the cavity to be taken negative)

$$\Rightarrow \frac{4}{3}\pi(R^3 - 1^3)\rho g (2 - R) = \frac{4}{3}\pi(1)^3\rho g(R - 1)$$

$$\Rightarrow (R^3 - 1^3)(2 - R) = (1^3)(R - 1)$$

$$\Rightarrow (R^2 + R + 1)(R - 1)(2 - R) = (R - 1)$$

(using identity)

$$\Rightarrow (R^2 + R + 1)(2 - R) = 1$$

9. A charge particle of mass m and charge q is released from rest in uniform electric field. Its graph between velocity (v) and distance (x) will be :

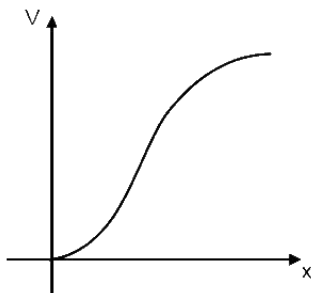

a.

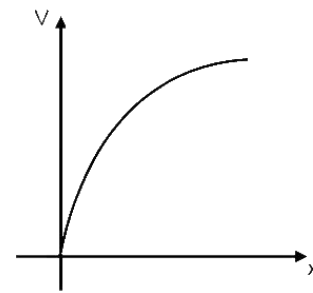

b.

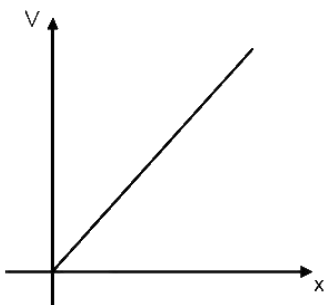

c.

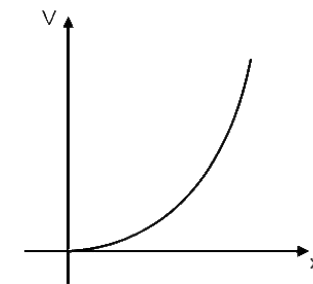

d.

Solution. (b)

Applying work energy theorem,

$$qEx = \frac{1}{2}mv^2$$

$$v^2 \propto x$$

Hence, solution will be option (b)

10. In full scale deflection current in galvanometer of 100Ω resistance is 1 mA . Resistance required in series to convert it into voltmeter of range 10 V .

a. $0.99 \text{ K}\Omega$

b. $9.9 \text{ K}\Omega$

c. $9.8 \text{ K}\Omega$

d. $10 \text{ K}\Omega$

Solution: (b)

$$V_0 = i_g R_g = 0.1 \text{ v}$$

$$v = 10 \text{ V}$$

$$R = R_g \left(\frac{v}{v_g} - 1 \right)$$

$$= 100 \times 99 = 9.9 \text{ K}\Omega$$

11. n moles of He and $2n$ moles of O_2 are mixed in a container. Then $\left(\frac{C_p}{C_v} \right)_{\text{mix}}$ will be

a. $\frac{19}{23}$

b. $\frac{13}{19}$

c. $\frac{19}{13}$

d. $\frac{23}{19}$

Solution: (c)

Using formula

$$C_{v_{\text{mix}}} = \frac{n_1 C_{v_1} + n_2 C_{v_2}}{n_1 + n_2}$$

$$= \frac{n \times \frac{3R}{2} + 2n \times \frac{5R}{2}}{3n} = \frac{13R}{6} \quad (\because \text{He is monoatomic and } \text{O}_2 \text{ is diatomic})$$

$$C_{p_{mix}} = C_{v_{mix}} + R = \frac{19R}{6}$$

$$\therefore \gamma_{mix} = \frac{C_{p_{mix}}}{C_{v_{mix}}} = \frac{19}{13}$$

12. A solid sphere of mass $m = 500 \text{ gm}$ is rolling without slipping on a horizontal surface. Find kinetic energy of the sphere if velocity of center of mass is 5 cm/sec .

a. $\frac{35}{4} \times 10^{-4} \text{ J}$
c. $21 \times 10^{-4} \text{ J}$

b. $\frac{35}{2} \times 10^{-4} \text{ J}$
d. $70 \times 10^{-3} \text{ J}$

Solution:(a)

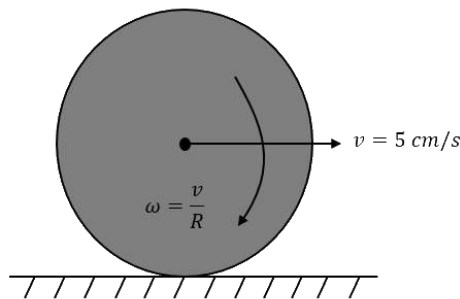

Total K.E. = Translational K.E + Rotational K.E.

$$= \frac{1}{2}mv^2 + \frac{1}{2}I\omega^2$$

$$= \frac{1}{2}mv^2 \left(1 + \frac{k^2}{R^2}\right)$$

k is radius of gyration.

$$= \frac{1}{2} \times \frac{1}{2} \times \left(\frac{5}{100}\right)^2 \left(1 + \frac{2}{5}\right)$$

$$= \frac{35}{4} \times 10^{-4} \text{ J}$$

13. Two square plates of side 'a' are arranged as shown in the figure. The minimum separation between plates is 'd' and one of the plates is inclined at small angle α with plane parallel to another plate. The capacitance of capacitor is (given α is very small)

- a. $\frac{\epsilon_0 a^2}{d} \left(1 - \frac{\alpha a}{d}\right)$ b. $\frac{\epsilon_0 a^2}{d} \left(1 - \frac{\alpha a}{2d}\right)$
 c. $\frac{\epsilon_0 a^2}{d} \left(1 + \frac{\alpha a}{2d}\right)$ d. $\frac{\epsilon_0 a^2}{d} \left(1 - \frac{\alpha a}{4d}\right)$

Solution:(b)

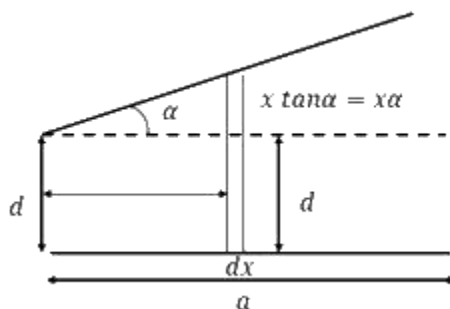

Let dC be the capacitance of the element of thickness dx

$$dC = \frac{\epsilon_0 a dx}{d + \alpha x}$$

These are effectively in parallel combination

So,

$$\begin{aligned} C &= \int dC \\ C &= \int_0^a \frac{\epsilon_0 a dx}{d + \alpha x} \\ \Rightarrow C &= \frac{\epsilon_0 a}{\alpha} [\ln(d + \alpha x)]_0^a \\ &= \frac{\epsilon_0 a}{\alpha} \left[\ln \left(1 + \frac{\alpha a}{d}\right) \right] \\ &\approx \frac{\epsilon_0 a^2}{d} \left(1 - \frac{\alpha a}{2d}\right) \end{aligned}$$

14. In YDSE path difference at a point on the screen is 8λ . Find ratio of intensity at this point with maximum intensity.

- a. 0.533
c. 0.234
b. 0.853
d. 0.123

Solution: (b)

In YDSE, the intensity at a point on the screen varies with the phase difference between the interfering light waves as:

$$I = I_0 \cos^2 \left(\frac{\Delta\phi}{2} \right)$$

Here, $\Delta\phi$ = phase difference between the interfering waves

I_0 = maximum intensity on the screen

$$\frac{I}{I_0} = \cos^2 \left[\frac{2\pi \times \Delta x}{\lambda} \right] = \cos^2 \left(\frac{\pi}{8} \right)$$
$$\frac{I}{I_0} = 0.853$$

15. In the given circuit switch is closed at $t = 0$. The charge flown in time $t = T_c$ (where T_c is time constant).

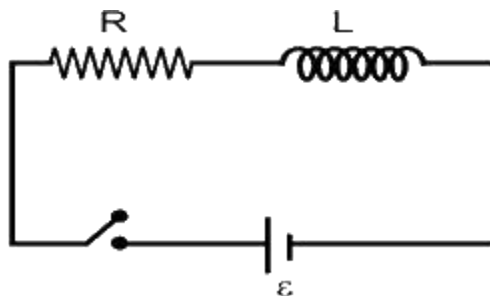

- a. $\frac{\epsilon L}{eR^2}$
c. $\frac{\epsilon L(1-\frac{1}{e})}{eR^2}$
b. $\frac{\epsilon L}{4eR^2}$
d. $\frac{\epsilon L}{eR}$

Solution:(a)

This is standard $L - R$ growth of current circuit.

$$i(t) = \frac{\varepsilon}{R} e^{-\frac{t}{Tc}}$$

Substituting in the integral ,

$$\begin{aligned} q &= \int_0^{Tc} (i) dt \\ &= \frac{\varepsilon}{R} \left[t - \frac{e^{-\frac{t}{Tc}}}{-\frac{1}{Tc}} \right]_0^{Tc} \\ &= \frac{\varepsilon L}{eR^2} \end{aligned}$$

16. A particle is dropped from height $h = 100 \text{ m}$, from surface of a planet. If in last $\frac{1}{2} \text{ s}$ of its journey it covers 19 m , then the value of acceleration due to gravity in that planet is: (Assume the radius of planet to be much larger than 100 m)

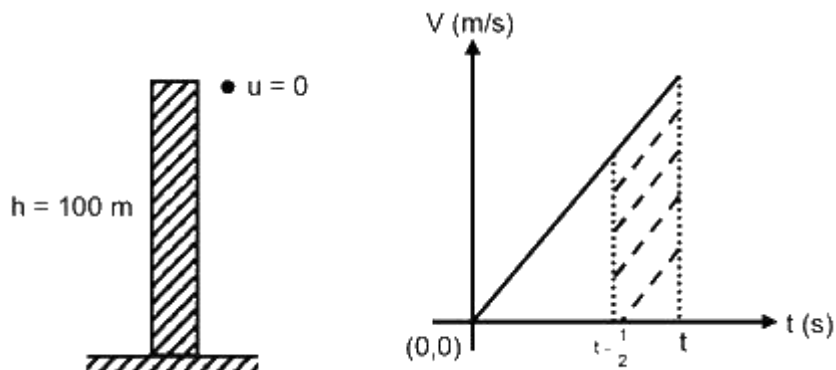

- a. 8 m/s^2
- c. 6 m/s^2

- b. 7 m/s^2
- d. 5 m/s^2

Solution:(a)

Since the radius of planet is much larger than 100 m , it's a uniformly accelerated motion.

So, Trapezium's area

$$s = \frac{g\left[t - \frac{1}{2} + t\right]}{2} \times \frac{1}{2} = 19 \quad \text{(i)}$$

$$\frac{1}{2}gt^2 = 100 \quad \text{(ii)}$$

Solving equations (i) and (ii), we get

$$g = 8 \text{ m/s}^2$$

17. Coming Soon

18. A simple pendulum of length 25.0 cm makes 40 oscillation in 50 sec . If resolution of stopwatch is 1 sec , then accuracy of g is (in %)

- a. 1.2
b. 3.2
c. 4.4
d. 5.4

Solution:(c)

$$T = 2\pi \sqrt{\frac{L}{g}}$$

$$g = L \cdot \left(\frac{2\pi}{T}\right)^2$$

$$\frac{\Delta g}{g} = 2 \frac{\Delta T}{T} + \frac{\Delta L}{L}$$

$$2 \left(\frac{1}{50}\right) + \frac{0.1}{25} = 4.4\%$$

19. An electron is moving initially with velocity $v_0\hat{i} + v_0\hat{j}$ in uniform electric field $\vec{E} = -E_0\hat{k}$. If initial wavelength of electron is λ_0 and mass of electron is m , find wavelength of electron as a function of time.

a.
$$\frac{\lambda_0}{\sqrt{1 + \frac{e^2 E_0^2}{m^2 v_0^2} t^2}}$$

b.
$$\frac{2\lambda_0}{\sqrt{1 + \frac{e^2 E_0^2}{m^2 v_0^2} t^2}}$$

c.
$$\frac{\lambda_0 m v_0}{e E_0 t}$$

d.
$$\frac{2\lambda_0 m v_0}{e E_0 t}$$

Solution:(b)

Momentum of an electron

$$p = mv = \frac{h}{\lambda}$$

$$\text{Initially } m(\sqrt{2}v_0) = \frac{h}{\lambda_0}$$

$$\text{Velocity as a function of time} = v_0\hat{i} + v_0\hat{j} + \frac{eE_0}{m}t\hat{k}$$

$$\text{So, wavelength } \lambda = \frac{h}{m\sqrt{2v_0^2 + \frac{e^2 E_0^2}{m^2}t^2}}$$

$$\Rightarrow \lambda = \frac{\lambda_0}{\sqrt{1 + \frac{e^2 E_0^2}{m^2 v_0^2} t^2}}$$

20. Output at terminal Y of given logic circuit.

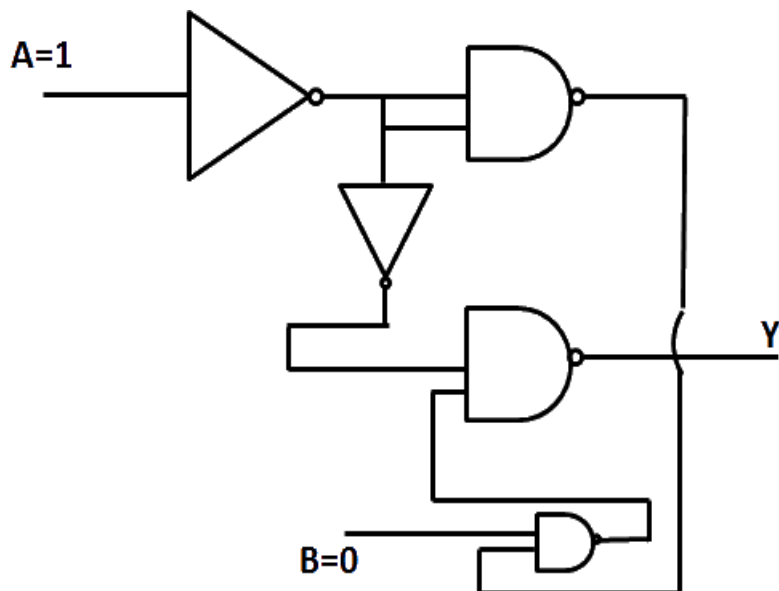

- a. 1
- b. 0
- c. Can't determine
- d. Oscillating between 0 and 1

Solution: b.

$$Y = \overline{\overline{A}B} \cdot \overline{A}$$

$$= \overline{\overline{A}B} + \overline{A}$$

$$= AB + \overline{A}$$

$$Y = 0 + 0 = 0$$

21. In H -spectrum wavelength of 1st line of Balmer series is $\lambda = 6561\text{\AA}$. Find out wavelength of 2nd line of same series in nm .

Solution: (486)

$$\frac{1}{\lambda} = RZ^2 \left(\frac{1}{n_1^2} - \frac{1}{n_2^2} \right)$$

$$\frac{1}{\lambda_1} = R(1)^2 \left(\frac{1}{2^2} - \frac{1}{3^2} \right) = \frac{5R}{36}$$

$$\frac{1}{\lambda_2} = R(1)^2 \left(\frac{1}{2^2} - \frac{1}{4^2} \right) = \frac{3R}{36}$$

$$\frac{\lambda_2}{\lambda_1} = \frac{20}{27}$$

$$\lambda_2 = \frac{20}{27} \times 6561 \text{ \AA} = 4860 \text{ \AA}$$

22. An EMW is travelling along z-axis is $\vec{B} = 5 \times 10^{-8} \hat{j} T$, $c = 3 \times 10^8 \text{ m/s}$ and frequency of wave is 25 Hz , then electric field in $\frac{\text{volt}}{\text{m}}$.

Solution:(15)

$$\frac{E}{B} = c$$

$$E = B \times c$$

Given,

$$\vec{B} = 5 \times 10^{-8} \hat{j} T \text{ and } C = 3 \times 10^8 \text{ m/s}$$

$$E = 15 \frac{\text{volt}}{\text{m}}$$

23. There are three containers C_1 , C_2 and C_3 filled with same material at different constant temperature. When we mix them in different quantity (volume) then we get some final temperature as shown in the table. Then find the value of final temperature θ as shown in the table.

C_1	C_2	C_3	$t(^{\circ}C)$
1 l	2 l	0	60
0	1 l	2 l	30
2 l	0	1 l	60
1 l	1 l	1 l	θ

Solution: (50)

Since, all the containers have same material, specific heat capacity is the same for all.

$$V_1\theta_1 + 2\theta_2 = (V_1+V_2)\theta_f$$

$$1\theta_1 + 1\theta_2 = (1 + 2)60$$

$$\theta_1 + 2\theta_2 = 180$$

$$0 \times \theta_1 + 1 \times \theta_2 + 2 \times \theta_3 = (1 + 2)30$$

$$\theta_2 + 2\theta_3 = 180$$

$$\theta_1 + 2\theta_2 + \theta_3 = (1 + 1 + 1)\theta$$

From equation. (1)+(2)+(3)

$$3\theta_1 + 3\theta_2 + 3\theta_3 = 450$$

Where, $\theta_1 + \theta_2 + \theta_3 = 150$

From (4) equation $150=30$

So, $\theta = 50^\circ C$

24. An asteroid of mass m ($m \ll m_E$) is approaching with a velocity 12 km/s when it is at distance of $9R$ from the surface of earth (where R is radius of earth). When it reaches at the surface of Earth, its velocity is (Nearest Integer) in km/s .

Solution: (16)

Taking, asteroid and earth as an isolated system conserving total energy.

$$KE_i + PE_i = KE_f + PE_f$$

$$\frac{1}{2}mu_0^2 + \left(-\frac{GMm}{10R}\right) = \frac{1}{2}mv^2 + \left(-\frac{GMm}{R}\right)$$

$$v^2 = u_0^2 + \frac{2GM}{R} \left[1 - \frac{1}{10}\right]$$

$$v = \sqrt{u_0^2 + \frac{9GM}{5R}}$$

Since, escape velocity from surface of earth is $11.2 \frac{\text{km}}{\text{sec}^2} = \sqrt{\frac{2GM}{R}}$

$$= \sqrt{12^2 + \frac{9(11.2)^2}{5}}$$

$$= \sqrt{256.9} \approx 16 \text{ km/s.}$$

25. Two batteries (connected in series) of same emf 10 V of internal resistances 20Ω and 5Ω are connected to a load resistance of 30Ω . Now an unknown resistance x is connected in parallel to the load resistance. Find value of x so that potential drop of battery having internal resistance 20Ω becomes zero.

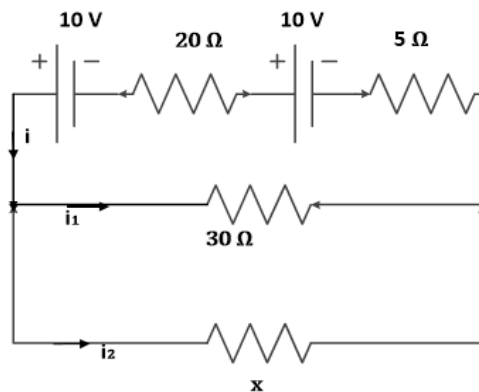

Solution: (30)

If V_1 and V_2 are terminal voltage across the two batteries.

$$V_1 = 0$$

$$V_1 = \varepsilon_1 - i \cdot r_1$$

$$0 = 10 - i \times 20$$

$$i = 0.5 \text{ A}$$

$$V_2 = 10 - 0.5 \times 5$$

$$V_2 = 7.5 \text{ V}$$

$$0.5 = \frac{7.5}{30} + \frac{7.5}{x}$$

$$\frac{7.5}{x} = 0.25$$

$$x = 30 \Omega$$