

SECTION-A

GENERAL APTITUDE

Q.1 The world is going through the worst pandemic in the past hundred years. The air travel industry is facing a crisis, as the resulting quarantine requirement for travelers led to weak demand.

In relation to the first sentence above, what does the second sentence do?

- (a) Second sentence entirely contradicts the first sentence.
- (b) States an effect of the first sentence.
- (c) The two statements are unrelated.
- (d) Restates an idea from the first sentence.

Ans. (b)

First option is wrong because second sentence does not contradict the first sentence. Third option is wrong because two sentences are related. Fourth option is wrong because the second sentence does not repeat the first one.

Hence second option is correct which shows the result of the cause.

End of Solution

Q.2 Consider a square sheet of side 1 unit. The sheet is first folded along the main diagonal. This is followed by a fold along its line of symmetry. The resulting folded shape is again folded along its line of symmetry. The area of each face of the final folded shape, in square units, equal to _____.

- (a) $\frac{1}{8}$
- (b) $\frac{1}{32}$
- (c) $\frac{1}{4}$
- (d) $\frac{1}{16}$

Ans. (a)

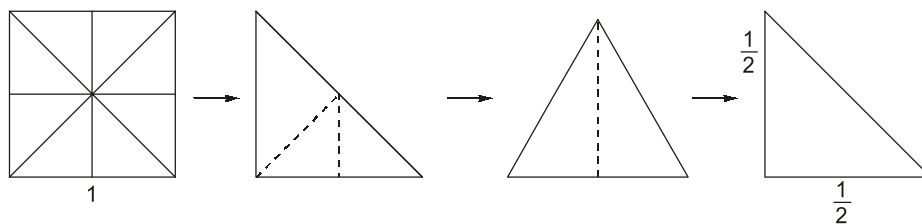

$$\text{Area} = \frac{1}{2} \times \frac{1}{2} \times \frac{1}{2} = \frac{1}{8}$$

End of Solution

- Q.3** The front door of Mr. X's house faces East. Mr. X leaves the house, walking 50 m straight from the back door that is situated directly opposite to the front door. He then turns to his right, walks for another 50 m and stops. The direction of the point Mr. X is now located at with respect to the starting point is _____.
- (a) South-East (b) North-West
(c) North-East (d) West

Ans. (b)

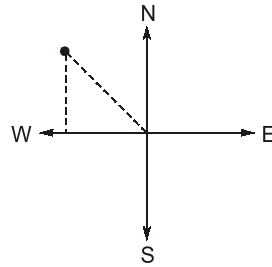

End of Solution

- Q.4** Five persons P, Q, R, S and T are to be seated in a row, all facing the same direction, but not necessarily in the same order. P and T cannot be seated at either end of the row. P should not be seated adjacent to S. R is to be seated at the second position from the left end of the row. The number of distinct seating arrangements possible is:
- (a) 2 (b) 3
(c) 4 (d) 5

Ans. (b)

The possible distinct arrangement are
S R P T Q, Q R P T S, S R T P Q
Hence, number of distinct sitting arrangement. = 3

End of Solution

- Q.5** A box contains 15 blue balls and 45 black balls. If 2 balls are selected randomly, without replacement, the probability of an outcome in which the first selected is a blue ball and the second selected is a black ball, is _____.
- (a) $\frac{45}{236}$ (b) $\frac{1}{4}$
(c) $\frac{3}{16}$ (d) $\frac{3}{4}$

Ans. (a)

The probability of first ball is blue and second ball is black is given as,

$$P = \frac{15}{60} \times \frac{45}{59} = \frac{45}{236}$$

End of Solution

Q.6 Consider the following sentences:

- (i) The number of candidates who appear for the GATE examination is staggering.
- (ii) A number of candidates from any class are appearing for the GATE examination.
- (iii) The number of candidates who appear for the GATE examination are staggering.
- (iv) A number of candidates from my class is appearing for the GATE examination.

Which of the above sentences are grammatically CORRECT?

- (a) (i) and (iii)
- (b) (i) and (ii)
- (c) (ii) and (iii)
- (d) (ii) and (iv)

Ans. (b)

“The number of” is singular and it takes singular verb. “A number of ” is plural and it takes plural verb.

End of Solution

Q.7 A digital watch X beeps every 30 seconds while watch Y beeps every 32 seconds. They beeped together at 10 AM.

The immediate next time that they will beep together is _____.

- (a) 11.00 AM
- (b) 10.08 AM
- (c) 10.42 AM
- (d) 10.00 PM

Ans. (b)

LCM of (30 and 32) is 480

480 seconds = 8 minutes

Hence, time will be 10.08 pm

End of Solution

Q.8 The ratio of the area of the inscribed circle to the area of circumscribed circle of an equilateral triangle is _____.

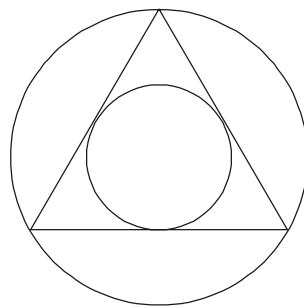

- (a) $\frac{1}{4}$
- (b) $\frac{1}{2}$
- (c) $\frac{1}{6}$
- (d) $\frac{1}{8}$

Ans. (a)

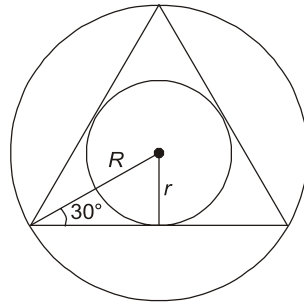

$$\sin 30^\circ = \frac{r}{R}$$

$$\text{Area ratio} = \frac{\pi r^2}{\pi R^2} = \sin^2 30 = \frac{1}{4}$$

End of Solution

Q.9 Given below are two statements 1 and 2, and two conclusions I and II.

Statement 1: All entrepreneurs are wealthy.

Statement 2: All wealthy are risk seekers.

Conclusion I: All risk seekers are wealthy.

Conclusion II: Only some entrepreneurs are risk seekers.

Based on the above statements and conclusions, which one of the following options is CORRECT?

- (a) Only conclusion I is correct
- (b) Only conclusion II is correct
- (c) Neither conclusion I nor II is correct
- (d) Both conclusions I and II are correct

Ans. (c)

Possible cases are:

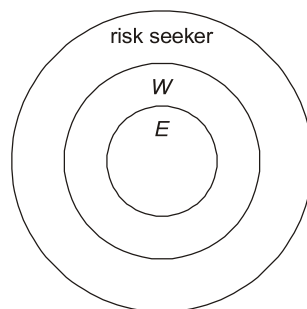

Conclusion-I is incorrect because some risk seekers are wealthy.

Conclusion-II is also incorrect because all the entrepreneurs are risk seekers as well as wealthy.

End of Solution

Q.10 If $\oplus \div \odot = 2$; $\oplus \div \Delta = 3$; $\odot + \Delta = 5$; $\Delta \times \otimes = 10$,

Then, the value of $(\otimes - \oplus)^2$, is:

- (a) 4 (b) 16
(c) 1 (d) 0

Ans. (c)

$$\frac{\oplus}{\odot} = 2, \frac{\oplus}{\Delta} = 3$$

$$\therefore \frac{\Delta}{\odot} = \frac{2}{3} \quad \dots(1)$$

$$\odot + \Delta = 5 \quad \dots(2)$$

From (1) and (2)

$$\Delta = 2, \odot = 3$$

and

$$\oplus = 6, 2 \times \otimes = 10$$

$$\otimes = 5$$

$$\Rightarrow (\otimes - \oplus)^2 = (5 - 6)^2 = 1$$

End of Solution



SECTION-B

TECHNICAL

Q.1 Let the superscript T represent the transpose operation. Consider the function $f(x) = \frac{1}{2}x^T Qx - r^T x$, where x and r are $n \times 1$ vectors and Q is a symmetric $n \times n$ matrix. The stationary point of $f(x)$ is

- (a) $\frac{r}{r^T r}$ (b) $Q^T r$
 (c) $Q^{-1} r$ (d) r

Ans. (c)

Let $Q = \begin{bmatrix} a & c \\ c & b \end{bmatrix}$, $x = \begin{bmatrix} x_1 \\ x_2 \end{bmatrix}$, $R = \begin{bmatrix} r_1 \\ r_2 \end{bmatrix}$

$$\begin{aligned} F(x) &= \frac{1}{2}(x_1, x_2) \begin{bmatrix} a & c \\ c & b \end{bmatrix} \begin{bmatrix} x_1 \\ x_2 \end{bmatrix} - [r_1 \ r_2] \begin{bmatrix} x_1 \\ x_2 \end{bmatrix} \\ &= \frac{1}{2} [ax_1^2 + bx_2^2 + 2cx_1x_2] - [r_1x_1 + r_2x_2] \end{aligned}$$

i.e. $U(x_1, x_2) = \frac{1}{2}ax_1^2 + \frac{1}{2}bx_2^2 + c_1x_1x_2 - r_1x_1 - r_2x_2$

Now, for critical point, $\frac{\partial U}{\partial x_1} = 0$ and $\frac{\partial U}{\partial x_2} = 0$

$$\Rightarrow ax_1 + cx_2 - r_1 = 0 \quad \text{and} \quad cx_2 + cx_1 - r_2 = 0$$

In matrix form we can write it as

$$\begin{bmatrix} a & c \\ c & b \end{bmatrix} \begin{bmatrix} x_1 \\ x_2 \end{bmatrix} = \begin{bmatrix} r_1 \\ r_2 \end{bmatrix}$$

$$\Rightarrow Qx = R$$

By multiplying both side by Q^{-1}

$$x = Q^{-1}R$$

End of Solution

Q.2 The demand and forecast of an item for five months are given in the table.

Month	Demand	Forecast
April	225	200
May	220	240
June	285	300
July	290	270
August	250	230

The Mean Absolute Percent Error (MAPE) in the forecast is _____%.
 (round off to two decimal places)

Ans. (8.07)(6 to 10)

Month	D_i	F_i	e_i	$\left \frac{e_i}{D_i} \times 100 \right $
April	225	200	25	11.11%
May	220	240	-20	9.09%
June	285	300	-15	5.26%
July	290	270	20	6.896%
August	250	230	20	8.0%
				$\sum \left \frac{e_i}{D_i} \times 100 \right = 40.356$

$$\text{MAPE} = \frac{\sum \left| \frac{e_i}{D_i} \times 100 \right|}{n} = 8.0712\%$$

End of Solution

- Q.3** Consider the system shown in the figure. A rope goes over a pulley. A mass, m , is hanging from the rope. A spring of stiffness, k , is attached at one end of the rope. Assume rope is inextensible, massless and there is no slip between pulley and rope.

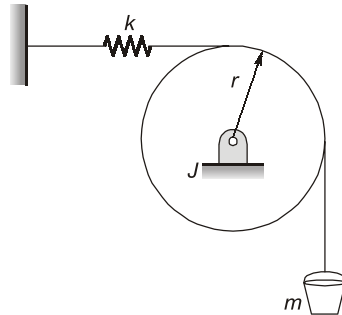

The pulley radius is r and its mass moment of inertia is J . Assume that the mass is vibrating harmonically about its static equilibrium position. The natural frequency of the system is

- (a) $\sqrt{\frac{kr^2}{J+mr^2}}$ (b) $\sqrt{\frac{kr^2}{J}}$
- (c) $\sqrt{\frac{kr^2}{J-mr^2}}$ (d) $\sqrt{\frac{k}{m}}$

Ans. (a)

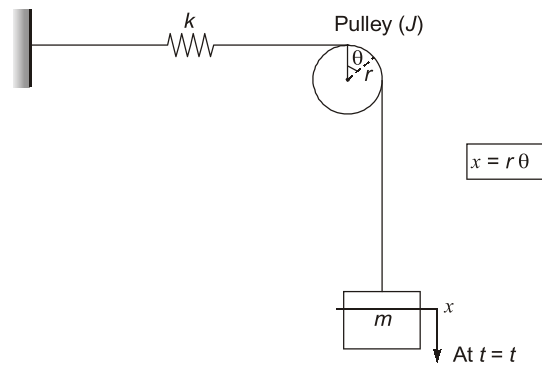

$$\begin{aligned}
 E &= \frac{1}{2} m \dot{x}^2 + \frac{1}{2} k x^2 + \frac{1}{2} I \omega^2 \\
 &= \frac{1}{2} m r^2 \dot{\theta}^2 + \frac{1}{2} k r^2 \theta^2 + \frac{1}{2} J \dot{\theta}^2 \\
 &= \frac{1}{2} [(J + m r^2) \dot{\theta}^2 + k r^2 \theta^2] = 0
 \end{aligned}$$

$$\frac{dE}{dt} = 0$$

$$(J + m r^2) \times 2 \dot{\theta} \ddot{\theta} + k r^2 2 \theta \dot{\theta} = 0$$

$$\left(\ddot{\theta} + \frac{k r^2}{J + m r^2} \right) \dot{\theta} = 0$$

$$\omega_n = \sqrt{\frac{k r^2}{J + m r^2}}$$

End of Solution

Q.4 Consider adiabatic flow of air through a duct. At a given point in the duct, velocity of air is 300 m/s, temperature is 330 K and pressure is 180 kPa. Assume that the air behaves as a perfect gas with constant $c_p = 1.005$ kJ/kgK. The stagnation temperature at this point is _____ K (round off to two decimal places.)

Ans. (374.70)(373 to 377)

$$M_1 = \frac{V_1}{\sqrt{\gamma R T_1}} = \frac{300}{\sqrt{1.4 \times 287 \times 330}} = 0.823$$

$$\frac{T_{01}}{T_1} = 1 + \frac{\gamma - 1}{2} M_1^2 = 1 + \frac{1.4 - 1}{2} (0.823)^2$$

$$\frac{T_{01}}{T_1} = 1.154$$

$$T_{01} = 374.7037 \text{ K}$$

End of Solution

Q.5 Daily production capacity of a bearing manufacturing company is 30000 bearings. The daily demand of the bearing is 15000, The holding cost per year of keeping a bearing in the inventory is ₹ 20. The setup cost for the production of a batch is ₹ 1800. Assuming 300 working days in a year, the economic batch quantity in number of bearings is _____ (in integer).

Ans. (40250)(40200 to 40300)

$$Q^* = \sqrt{\frac{2D \times C_0}{C_h} \times \frac{P}{P-d}}$$

$$= \sqrt{\frac{2 \times 15000 \times 300 \times 1800}{20} \times \left(\frac{30000}{30000 - 15000} \right)}$$

$$= 40249.2 \approx 40250 \text{ units}$$

End of Solution

Q.6 A spot welding operation performed on two pieces of steel yielded a nugget with a diameter of 5 mm and a thickness of 1 mm. The welding time was 0.1 s. The melting energy for the steel is 20 J/mm³. Assuming the heat conversion efficiency as 10%, the power required for performing the spot welding operation is _____ kW (round off to two decimal places).

Ans. (39.25)(39 to 40)

Heat transfer efficiency = 10%

Energy required to melt = 20 J/mm³

Diameter of nugget = 5 mm

Thickness = 1 mm

Time = 0.1 second

$$\text{Heat required to melt, } Q = 20 \text{ J/mm}^3 \times \frac{\pi}{4} (5)^2 \times 1 = 392.5 \text{ J}$$

$$\text{Power} = \frac{\text{Heat required to melt}}{\text{Time}}$$

$$P = \frac{392.5}{0.1} \text{ J/s}$$

$$P = 3925 \text{ J/s} = 3925 \text{ W}$$

$$\text{Actual power supplied} = \frac{3925}{\eta_{th}}$$

$$\eta_{th} = 10\%$$

$$P = \frac{3925}{0.1} = 39250 \text{ W} = 39.25 \text{ kW}$$

End of Solution

Q.7 The controlling force curves P, Q and R for a spring controlled governor are shown in the figure, where r_1 and r_2 are any two radii of rotation,

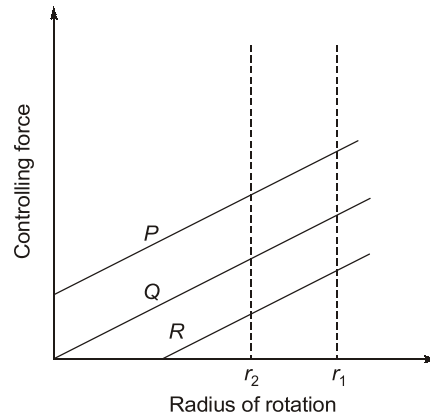

The characteristics shown by the curves are

- (a) P - Unstable: Q - Isochronous: R - Stable
- (b) P- Stable: Q - Isochronous; R - Unstable
- (c) P - Stable: Q - Unstable: R - Isochronous
- (d) P - Unstable: Q - Stable: R - Isochronous

Ans. (a)

End of Solution

Q.8 A 76.2 mm gauge block is used under one end of a 254 mm sine bar with roll diameter of 25.4 mm. The height of gauge blocks required at the other end of the sine bar to measure an angle of 30° is _____ mm (round off to two decimal places).

Ans. 203.2 (200 to 206)

Case-I:

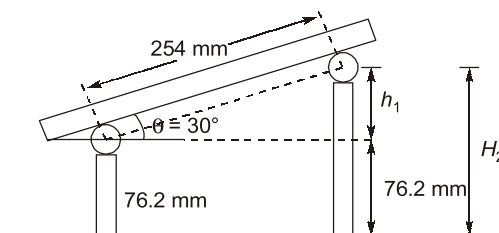

$$\sin 30^\circ = \frac{h_1}{254}$$

or

$$h_1 = 254 \sin 30^\circ = 127 \text{ mm}$$

$$H_2 = 76.2 + 127 = 203.2 \text{ mm}$$

Case-II:

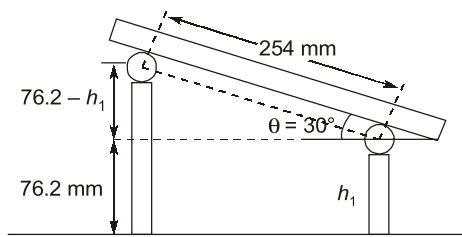

$$\sin 30^\circ = \frac{76.2 - h_1}{254}$$

or
$$h_1 = 76.2 - 254 \sin 30^\circ$$

$$= -50.8 \text{ mm}$$

Which is not feasible.
 Therefore final answer 203.2 mm.

End of Solution

Q.9 Ambient air flows over a heated slab having flat, top surface at $y = 0$. The local temperature (in Kelvin) profile within the thermal boundary layer is given by $T(y) = 300 + 200 \exp(-5y)$, where y is the distance measured from the slab surface in meters. If the thermal conductivity of air is $1.0 \text{ W/m}\cdot\text{K}$ and that of the slab is $100 \text{ W/m}\cdot\text{K}$, then the magnitude of temperature gradient $\left. \frac{dT}{dy} \right|_{y=0}$ within the slab at $y = 0$ is _____ K/m (round off to the nearest integer).

Ans. (10)(10 to 10)

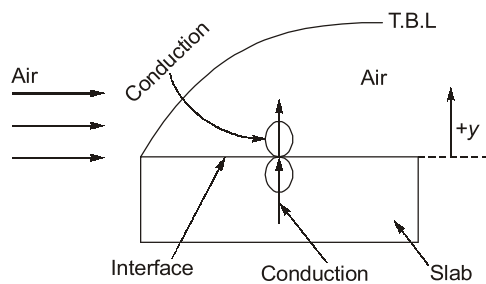

Given that

Temp. variation of air, $T = 300 + 200 e^{-5y}$

$$K_{\text{air}} = 1 \text{ W/m}\cdot\text{K}$$

$$K_{\text{slab}} = 100 \text{ W/m}\cdot\text{K}$$

$$\left. \frac{dT}{dy} \right|_{y=0, \text{ slab}} = ?$$

Applying surface energy balance at interface ($y = 0$)

$$\begin{aligned}
 N &= 900 \cos \theta + 750 \sin \theta \\
 N &= 900 \cos 30^\circ + 750 \sin 30^\circ \\
 &= 1154.4228 \text{ N} \\
 F_{\max} + 900 \sin 30^\circ &= 750 \cos 30^\circ \\
 \mu N &= 199.519 \\
 \mu &= \frac{199.519}{1154.4228} \\
 \mu &= 0.1728
 \end{aligned}$$

End of Solution

Q.14 The wheels and axle system lying on a rough surface is shown in the figure.

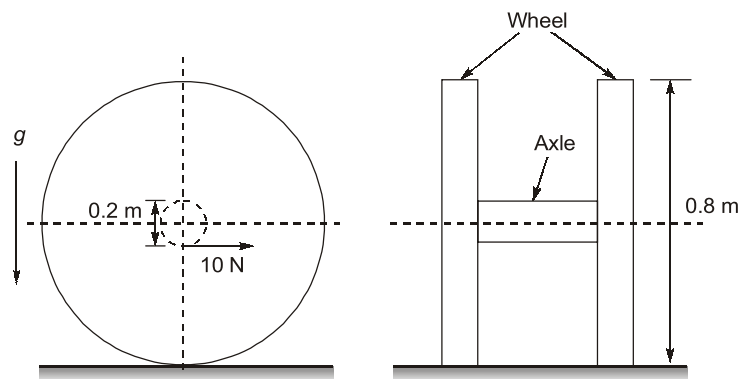

Each wheel has diameter 0,8 m and mass 1 kg. Assume that the mass of the wheel is concentrated at rim and neglect the mass of the spokes. The diameter of axle is 0.2 m and its mass is 1.5 kg. Neglect the moment of inertia of the axle and assume $g = 9.8 \text{ m/s}^2$. An effort of 10 N is applied on the axle in the horizontal direction shown at mid span of the axle. Assume that the wheels move on a horizontal surface without slip. The acceleration of the wheel axle system in horizontal direction is _____ m/s^2 (round off to one decimal place).

Ans. (1.3636)(1 to 2)

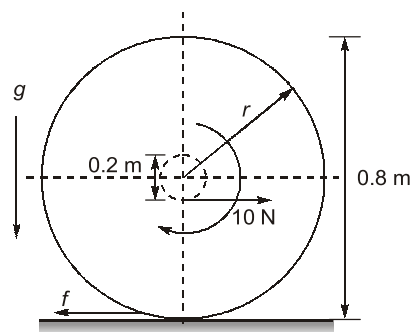

$$m = 1 \text{ kg/wheel}$$

$$m_{\text{axle}} = 1.5 \text{ kg}$$

$$10 - 2f = 3.5a \rightarrow \text{NSL}$$

$$10 - 2f = 3.5\alpha$$

$$10 - 2f = 1.4\alpha$$

$$\dots(1) \quad [r = 0.4 \text{ m}]$$

$$\Sigma T_{cm} = T_{cm}\alpha$$

$$2fr - 10 \times 0.1 = 2mr^2 \alpha$$

$$0.8f - 1 = 2 \times 1 \times 0.4^2 \alpha$$

$$0.8f - 1 = 0.32\alpha$$

$$\dots(2)$$

from (1)

$$\frac{10 - 1.4\alpha}{2} = f$$

$$\Rightarrow f = 5 - 0.7\alpha$$

Using eq. (2)

$$0.8(5 - 0.7\alpha) - 1 = 0.32\alpha$$

$$4 - 0.56\alpha - 1 = 0.32\alpha$$

$$3 = (0.32 + 0.56)\alpha$$

$$\Rightarrow \alpha = \frac{3}{0.88}$$

$$\alpha = 3.409 \text{ rad/s}^2$$

$$a_{cm} = r\alpha$$

$$a_{cm} = 1.3636 \text{ m/s}^2$$

End of Solution

Q.15 The size distribution of the powder particles used in Powder Metallurgy process can be determined by

(a) Laser absorption

(b) Laser penetration

(c) Laser scattering

(d) Laser reflection

Ans. (c)

End of Solution

Q.16 Consider the mechanism shown in the figure. There is rolling contact without slip between the disc and ground.

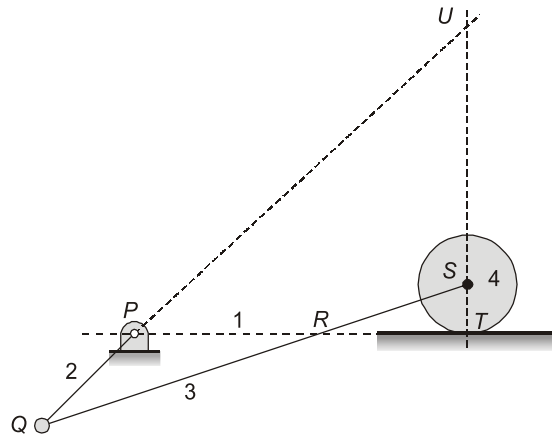

Select the correct statement about instantaneous centers in the mechanism.

- (a) Only points P , Q , R , S and U are instantaneous centers of mechanism
- (b) Only points P , Q , S and T are instantaneous centers of mechanism
- (c) Only points P , Q and S are instantaneous centers of mechanism
- (d) Only points P , Q , R , S , T and U are instantaneous centers of mechanism

Ans. (d)

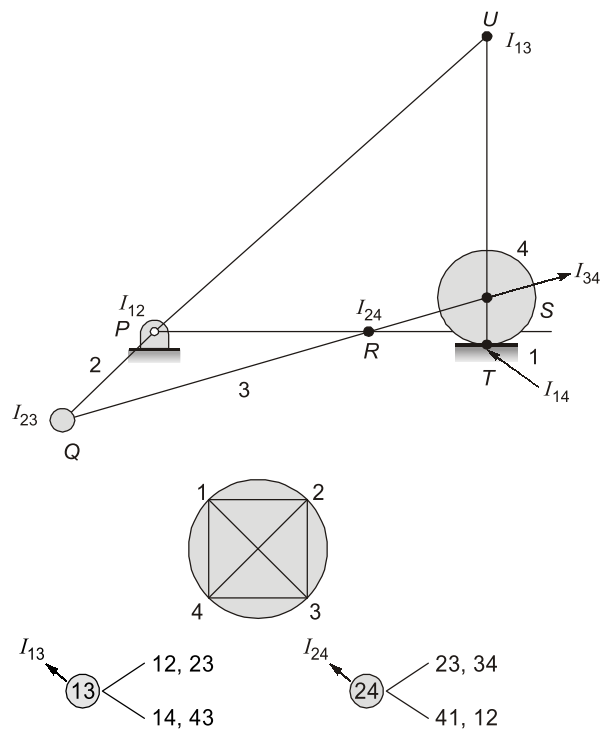

Points P , Q , R , S , T and U are instantaneous centers of mechanism.

End of Solution

Q.17 A cantilever beam with a uniform flexural rigidity ($EI = 200 \times 10^6 \text{ N}\cdot\text{m}^2$) is loaded with a concentrated force at its free end. The area of the bending moment diagram corresponding to the full length of the beam is $10000 \text{ N}\cdot\text{m}^2$. The magnitude of the slope of the beam at its free end is _____ micro radian (round off to the nearest integer).

Ans. (50)(48 to 52)

Assume:

$$A = 10000 \text{ N}\cdot\text{m}^2$$

$$EI = 200 \times 10^6 \text{ N}\cdot\text{m}^2$$

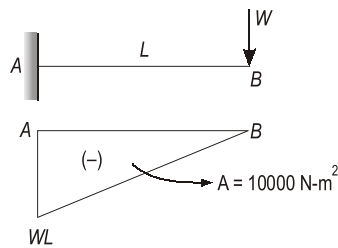

As per moment area first theorem.

$$\theta_B - \theta_A = \left(\frac{A}{EI} \right) AB$$

$$\theta_B - 0 = \frac{10000}{200 \times 10^6} = 0.5 \times 10^{-4} \text{ radians}$$

$$\theta_B = 50 \mu \text{ radians}$$

End of Solution

Q.18 A shell and tube heat exchanger is used as a steam condenser. Coolant water enters the tube at 300 K at a rate of 100 kg/s . The overall heat transfer coefficient is $1500 \text{ W/m}^2\cdot\text{K}$, and total heat transfer area is 400 m^2 . Steam condenses at a saturation temperature of 350 K . Assume that the specific heat of coolant water is $4000 \text{ J/kg}\cdot\text{K}$. The temperature of the coolant water coming out of the condenser is _____ K (round off to the nearest integer).

Ans. 339 (337 to 341)

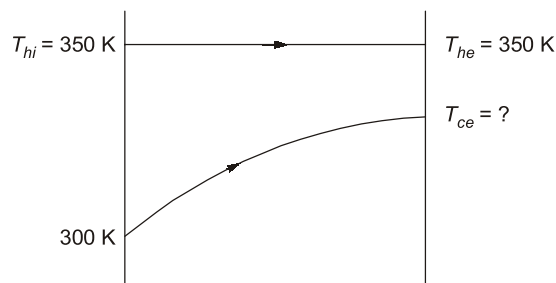

$$NTU = \frac{UA}{(\dot{m}c_p)_{\text{small}}} = \frac{1500 \times 400}{100 \times 4000} = 1.5$$

$$\epsilon_{HE} = 1 - e^{-NTU} = \frac{T_{ce} - T_{ci}}{T_{hi} - T_{ci}} = \frac{T_{ce} - 300}{350 - 300} = 0.7768$$

$$T_{ce} = 338.84 \text{ K} \approx 339 \text{ K}$$

End of Solution

Q.19 A column with one end fixed and one end free has a critical buckling load of 100 N. For the same column, if the free end is replaced with a pinned end then the critical buckling load will be _____ N (round off to the nearest integer).

Ans. (800)(800 to 840)

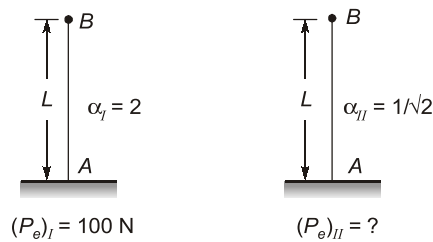

For a given material in 0.1 and length,

$$P_e \propto \frac{1}{\alpha^2}$$

where,

α = length fixity coefficient
 P_e = Buckling or critical load.

$$\frac{(P_e)_{II}}{(P_e)_I} = \left(\frac{\alpha_I}{\alpha_{II}} \right)^2 = \left(\frac{2L}{1/\sqrt{2}} \right)^2 = 8$$

$$(P_e)_{II} = 8(P_e)_I = 800 \text{ N}$$

End of Solution

Q.20 A steel cubic block of side 200 mm is subjected to hydrostatic pressure of 250 N/mm². The elastic modulus is 2×10^5 N/mm² and Poisson's ratio is 0.3 for steel. The side of the block is reduced by _____ mm (round off to two decimal places).

Ans. (0.1)(0.08 to 0.12)

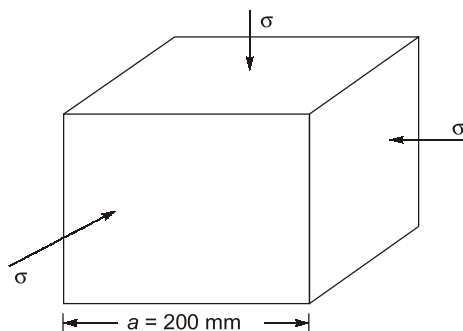

Ans. (d)

$$\begin{aligned}u &= 2xyt \\v &= -y^2t \\ \frac{dx}{u} &= \frac{dy}{v} = \frac{dz}{w} \\ \frac{dx}{2xyt} &= \frac{dy}{-y^2t} \\ -ydx &= 2xdy \\ \ln xy^2 &= C \\ xy^2 &= 1\end{aligned}$$

End of Solution

Q.24 In a pure orthogonal turning by a zero rake angle single point carbide cutting tool, the shear force has been computed to be 400 N. If the cutting velocity, $V_c = 100$ m/min, depth of cut, $t = 2.0$ mm, feed, $s_0 = 0.1$ mm/revolution and chip velocity. $V_f = 20$ m/min, then the shear strength τ_s of the material will be _____ MPa (round off to two decimal places).

Ans. (392.23)(388 to 400)

$$\begin{aligned}\alpha &= 0^\circ \\ F_s &= 400 \text{ N} \\ \text{Cutting velocity (V)} &= 100 \text{ m/min (} V_c \text{)} \\ d &= 2.0 \text{ mm (} t \text{)} \\ f &= 0.1 \text{ mm/rev (} S_0 \text{)} \\ \text{Chip velocity (} V_c \text{)} &= 20 \text{ m/min (} V_f \text{)} \\ r &= \frac{t}{t_c} = \frac{l_c}{l} = \frac{V_c}{V} \quad (V_c = \text{chip velocity; } V = \text{cutting velocity)} \\ &= \frac{20}{100} = 0.2 \\ \tan \phi &= \frac{r \cos \alpha}{1 - r \sin \alpha} = \frac{0.2 \cos 0^\circ}{1 - 0.2 \sin 0^\circ} = 0.2 \\ \phi &= 11.31^\circ \\ \tau_s &= \frac{F_s}{A_s} = \frac{F_s}{\left(\frac{bt}{\sin \phi}\right)} = \frac{F_s \sin \phi}{fd} \\ t &= f \sin 90^\circ \\ b &= d \sin 90^\circ \\ bt &= fd \\ &= \frac{400 \sin 11.31^\circ}{0.1 \times 2.0} \text{ N/mm}^2 \\ &= 392.23 \text{ MPa}\end{aligned}$$

End of Solution

Q.25 Ambient pressure, temperature, and relative humidity at a location are 101 kPa, 300 K, and 60%, respectively. The saturation pressure of water at 300 K is 3.6 kPa. The specific humidity of ambient air is _____ g/kg of dry air.

- (a) 13.6 (b) 35.1
(c) 21.4 (d) 21.9

Ans. (a)

$$\begin{aligned}\phi &= 0.6 \\ \frac{P_v}{P_{vs}} &= 0.6 \\ P_{vs} &= 3.6 \text{ kPa} \\ P_v &= 0.6 \times 3.6 \text{ kPa} \\ P_v &= 2.16 \text{ kPa} \\ \omega &= 0.622 \left(\frac{P_v}{P - P_v} \right) \\ &= 0.622 \left(\frac{2.16}{101 - 2.16} \right) \\ &= 0.01358 \text{ kg of water vapour/kg of dry air} \\ &= 13.58 \text{ g/kg of dry air}\end{aligned}$$

End of Solution

Q.26 The von Mises stress at a point in a body subjected to forces is proportional to the square root of the

- (a) distortional strain energy per unit volume
(b) dilatational strain energy per unit volume
(c) plastic strain energy per unit volume
(d) total strain energy per unit volume

Ans. (a)

Condition for failure as per M.D.E.T.

Distortion energy per unit volume under tri-axial state of stress > Distortion energy per unit volume under uni-axial state of stress.

$$\text{Hence, } \left(\frac{1+\mu}{6E} \right) \left[(\sigma_1 - \sigma_2)^2 + (\sigma_2 - \sigma_3)^2 + (\sigma_1 - \sigma_3)^2 \right] > \left(\frac{1+\mu}{3E} \right) (S_{yt})^2$$

$$(\sigma_1 - \sigma_2)^2 + (\sigma_2 - \sigma_3)^2 + (\sigma_1 - \sigma_3)^2 > 2(S_{yt})^2$$

$$\sqrt{\sigma_1^2 + \sigma_2^2 + \sigma_3^2 + \sigma_1\sigma_2 - \sigma_2\sigma_3 - \sigma_1\sigma_3} > (S_{yt}) \text{ (Von Mises effective stress)}$$

S_{yt} = Von Mises effective stress is defined as the uni-axial yield stress that would create same distortion energy created by the tri-axial state of stress.

End of Solution

Q.27 A factory produces m ($i = 1, 2, \dots, m$) products each of which requires processing on n ($j = 1, 2, \dots, n$) workstations. Let a_{ij} be the amount of processing time that one unit of the i^{th} product requires on the j^{th} workstation. Let the revenue from selling one unit of the i^{th} product be r_i and h_i be the holding cost per unit per time period for the i^{th} product. The planning horizon consists of T ($t = 1, 2, \dots, T$) time periods. The minimum demand that must be satisfied in time period t is d_{it} , and the capacity of the j^{th} workstation below, with decision variables S_{it} (amount of product i sold in time period t), X_{it} (amount of product i manufactured in time period t) and I_{it} (amount of product i held in inventory at the end of time period t).

$$\max \sum_{t=1}^T \sum_{i=1}^m (r_i S_{it} - h_i I_{it})$$

$$S_{it} \geq d_{it} \quad \forall i, t$$

< capacity constraint >

< inventory balance constraint >

$$X_{it}, S_{it}, I_{it} \geq I_{i0} = 0$$

The capacity constraints and inventory balance constraints for this formulation respectively are

(a) $\sum_i^m a_{ij} X_{it} \leq d_{it} \quad \forall i, t$ and $I_{it} = I_{i,t-1} + X_{it} - S_{it} \quad \forall i, t$

(b) $\sum_i^m a_{ij} X_{it} \leq d_{it} \quad \forall i, t$ and $I_{it} = I_{i,t-1} + S_{it} - X_{it} \quad \forall i, t$

(c) $\sum_i^m a_{ij} X_{it} \leq c_{jt} \quad \forall j, t$ and $I_{it} = I_{i,t-1} + X_{it} - S_{it} \quad \forall i, t$

(d) $\sum_i^m a_{ij} X_{it} \leq c_{jt} \quad \forall i, t$ and $I_{it} = I_{i,t-1} + X_{it} - d_{it} \quad \forall i, t$

Ans. (c)

$m \rightarrow i \dots m \leftarrow$ product

$n \rightarrow j \dots n \leftarrow$ workstation

$a_{ij} \rightarrow$ time

$r_i \rightarrow$ selling price

$h_i \rightarrow$ holding cost

$T \rightarrow t = 1, 2, \dots, T$

$d_{it} \rightarrow$ demand of product in time t

$c_{jt} \rightarrow$ capacity of workstation in time t

$S_{it} \rightarrow$ Number of product sold in time t

$X_{it} \rightarrow$ Number of product produced in time t

$I_{it} \rightarrow$ Number of product i hold in inventory at end of period t

Capacity constraint

$$a_{ij} X_{it} \leq c_{jt}$$

Inventory constraint

$$I_{it} = I_{i,t-1} + X_{it} - S_{it}$$

End of Solution

Q.28 A plane truss $PQRS$ ($PQ = RS$, and $\angle PQR = 90^\circ$) is shown in the figure.

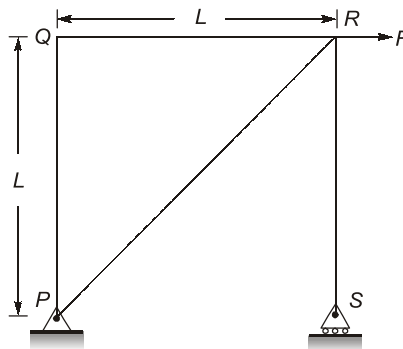

The forces in the members PR and RS , respectively, are _____.

- (a) $F\sqrt{2}$ (tensile) and F (tensile)
- (b) $F\sqrt{2}$ (tensile) and F (compressive)
- (c) F (compressive) and $F\sqrt{2}$ (compressive)
- (d) F (tensile) and $F\sqrt{2}$ (tensile)

Ans. (b)

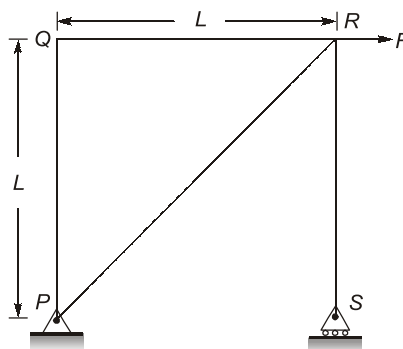

Joint C,

$$\Sigma F_H = 0$$

$$\Rightarrow F_{PR} \sin 45^\circ = F$$

$$F_{PR} = \sqrt{2}F \text{ (Tensile)}$$

$$\Rightarrow F_{PR} \cos 45^\circ = F_{RS}$$

$$\Sigma F_V = 0$$

$$F_{RS} = \cancel{\sqrt{2}}F \times \frac{1}{\cancel{\sqrt{2}}}$$

$$\Rightarrow F_{RS} = F \text{ (Comp.)}$$

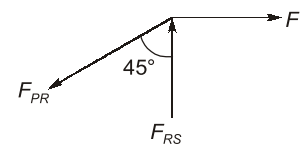

End of Solution

Q.29 Consider the open feed water heater (FWH) shown in the figure given below:

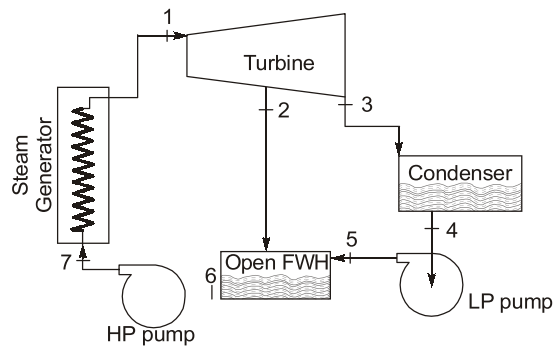

Specific enthalpy of steam at location 2 is 2624 kJ/kg, specific enthalpy of water at location 5 is 226.7 kJ/kg and specific enthalpy of saturated water at location 6 is 708.6 kJ/kg. If the mass flow rate of water entering the open feed water heater (at location 5) is 100 kg/s then the mass flow rate of steam at location 2 will be _____ kg/s (round off to one decimal place).

Ans. (25.2)(25 to 25.4)

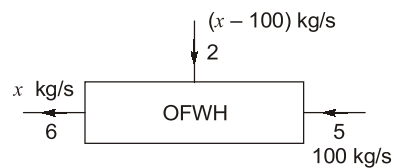
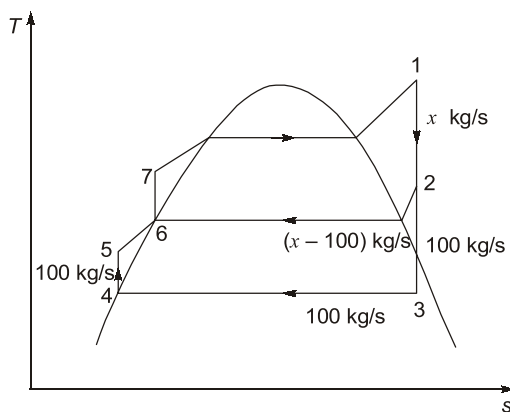

$$100h_5 + (x - 100)h_2 = xh_6$$

$$100 \times 226.7 + (x - 100)2624 = 708.6x$$

$$22670 + 2624x - 262400 = 708.6x$$

$$2624x - 708.6x = 239730$$

$$1915.4x = 239730$$

$$x = 125.159 \approx 125.2 \text{ kg/s}$$

Mass flow rate at state 2 $(x - 100) = 25.2$ kg/s

End of Solution

Q.30 The figure shows the relationship between fatigue strength (S) and fatigue life (N) of a material. The fatigue strength of the material for a life of 1000 cycles is 450 MPa, while its fatigue strength for a life of 10^6 cycles is 150 MPa.

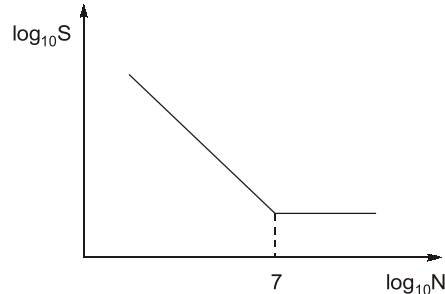

The life of a cylindrical shaft made of this material subjected to an alternating stress of 200 MPa will then be _____ cycles (round off to the nearest integer).

Ans. (163841)(152000 to 165000)

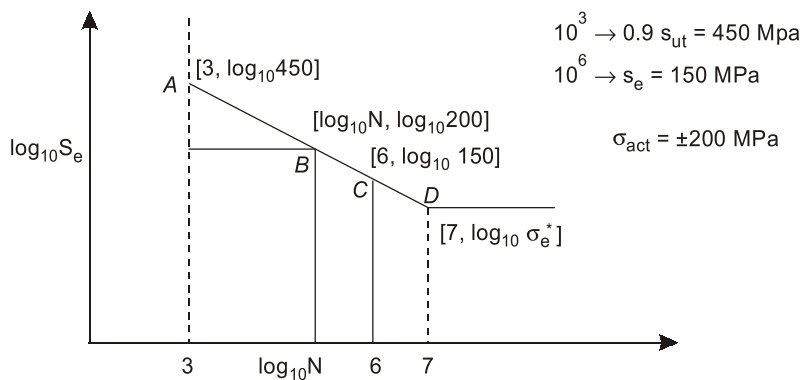

Equation of line AB:

$$y - y_1 = \frac{(y_2 - y_1)}{(x_2 - x_1)} [x - x_1]$$

$$\log_{10} 200 - \log_{10} 450 = \frac{\log_{10} 150 - \log_{10} 450}{(6 - 3)} [\log_{10} N - 3]$$

$$N = 163840.580 \text{ cycles}$$

End of Solution

Q.31 A surface grinding operation has been performed on a Cast Iron plate having dimensions 300 mm (length) x 10 mm (width) x 50 mm (height). The grinding was performed using an alumina wheel having a wheel diameter of 150 mm and wheel width of 12 mm. The grinding velocity used is 40 m/s, table speed is 5 m min, depth of cut per pass is 50 μ m and the number of grinding passes is 20. The average tangential and average normal forces for each pass are found to be 40 N and 60 N respectively. The value of the specific grinding energy under the aforesaid grinding conditions is _____ J/mm³ (round off to one decimal place).

Ans. 38.40 (38 to 39)

$$\begin{aligned} \text{Power} &= F_c \cdot V \\ &= 40\text{N} \times 40\text{ m/s} = 1600\text{ W} \end{aligned}$$

$$\begin{aligned} \text{MRR} &= 10 \times 0.050 \times \frac{5000}{60} \text{ mm}^3/\text{s} \\ &= 41.667 \text{ mm}^3/\text{s} \end{aligned}$$

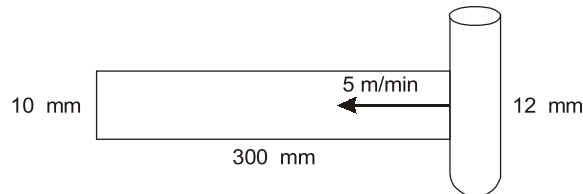

$$e = \frac{\text{Power}}{\text{MRR}} = \frac{1600\text{J/s}}{41.667\text{mm}^3/\text{s}} = 38.40 \text{ J/mm}^3$$

End of Solution

Q.32 If the Laplace transform of a function $f(t)$ is given by $\frac{s+3}{(s+1)(s+2)}$, then $f(0)$ is

- (a) $\frac{1}{2}$ (b) 0
(c) 1 (d) $\frac{3}{2}$

Ans. (c)

By using partial fraction concept.

$$f(t) = L^{-1} \left[\frac{s+3}{(s+1)(s+2)} \right]$$

$$= L^{-1} \left[\frac{2}{s+1} - \frac{1}{s+2} \right]$$

\Rightarrow

$$f(t) = 2e^{-t} - e^{-2t}$$

So,

$$f(0) = 2e^0 - e^0 = 2 - 1 = 1$$

End of Solution

Q.33 For a two-dimensional, incompressible flow having velocity components u and v in the x and y directions, respectively, the expression

$$\frac{\partial(u^2)}{\partial x} + \frac{\partial(uv)}{\partial y}$$

can be simplified to

(a) $2u \frac{\partial u}{\partial x} + u \frac{\partial v}{\partial y}$

(b) $u \frac{\partial u}{\partial x} + u \frac{\partial v}{\partial y}$

(c) $u \frac{\partial u}{\partial x} + v \frac{\partial u}{\partial y}$

(d) $2u \frac{\partial u}{\partial x} + v \frac{\partial u}{\partial y}$

Ans. (c)

$$\frac{\partial(u^2)}{\partial x} + \frac{\partial(uv)}{\partial y}$$

By differentiating:

$$\Rightarrow 2u \left[\frac{\partial u}{\partial x} \right] + u \frac{\partial v}{\partial y} + v \frac{\partial u}{\partial y}$$

$$\Rightarrow u \frac{\partial u}{\partial x} + \left[u \frac{\partial u}{\partial x} + u \frac{\partial v}{\partial y} \right] + v \frac{\partial u}{\partial y}$$

According to continuity eq. : $\frac{\partial u}{\partial x} + \frac{\partial v}{\partial y} = 0$

So, $u \frac{\partial u}{\partial x} + v \frac{\partial u}{\partial y}$

End of Solution

Q.34 Value of $\int_4^{5.2} \ln x dx$ using Simpson's one-third rule with interval size 0.3 is

(a) 1.60

(b) 1.83

(c) 1.51

(d) 1.06

Ans. (b)

Here $f(x) = \log x$

$a = 4, b = 5.2, h = 0.3$

So, $n = \frac{b-a}{h} = \frac{5.2-4}{0.3} = 4$

x	4	4.3	4.6	4.9	5.2
y	$\log 4$	$\log 4.3$	$\log 4.6$	$\log 4.9$	$\log 5.2$
	y_0	y_1	y_2	y_3	y_4

As per Simpson's 1/3rd rule

$$\int_4^{5.2} \log x dx = \frac{h}{3} [y_0 + y_4 + 4(y_1 + y_3) + 2(y_2)]$$
$$= 1.8272 \approx 1.83$$

End of Solution

Q.35 A cast product of a particular material has dimensions 75 mm × 125 mm × 20 mm. The total solidification time for the cast product is found to be 2.0 minutes as calculated using Chvorinov's rule having the index, $n = 2$. If under the identical casting conditions, the cast product shape is changed to a cylinder having diameter = 50 mm and height = 50 mm, the total solidification time will be _____ minutes (round off to two decimal places).

Ans. (2.83)(2.60 to 3.00)

Casting dimensions = 75 mm × 125 mm × 20 mm

Total solidification time $(t_s)_{cu} = 2.0$ min.

Cylindrical casting = $H = D = 50$ mm.

Total solidification Time $(t_s)_{cy} = ?$

Chvorinov's rule,

$$t_s \propto \left(\frac{V}{A}\right)^n \quad n=2$$

$$\frac{(t_s)_{cu}}{(t_s)_{cy}} = \frac{\left(\frac{V}{A}\right)_{cu}^2}{\left(\frac{V}{A}\right)_{cy}^2}$$

$$\left(\frac{V}{A}\right)_{cy} = \frac{\frac{\pi}{4} d^2 h}{2 \frac{\pi}{4} d^2 h + \pi d h}$$

$$h = d$$

$$\left(\frac{V}{A}\right)_{cy} = \frac{d}{6}$$

$$\frac{(t_s)_{cu}}{(t_s)_{cy}} = \frac{\left[\frac{75 \times 125 \times 20}{2(75 \times 125 + 125 \times 20 + 20 \times 75)} \right]^2}{\left(\frac{50}{6}\right)^2}$$

$$\frac{2}{(t_s)_{cy}} = \frac{49.131}{69.44} = 0.7075$$

$$(t_s)_{cy} = 2.83 \text{ min.}$$

End of Solution

Q.36 A rigid tank of volume 50 m^3 contains a pure substance as a saturated liquid vapour mixture at 400 kPa . Of the total mass of the mixture, 20% mass is liquid and 80% mass is vapour. Properties at 400 kPa are: Saturation temperature, $T_{\text{sat}} = 143.61^\circ\text{C}$; Specific volume of saturated liquid. $v_f = 0.001084 \text{ m}^3/\text{kg}$; Specific volume of saturated vapour. $v_g = 0.46242 \text{ m}^3/\text{kg}$. The total mass of liquid vapour mixture in the tank is _____ kg (round off to the nearest integer).

Ans. (135)(134 to 136)

$$\begin{aligned} V_{\text{total}} &= v_l + v_v \\ &= v_f \times m_l + v_g \times m_v \\ 50 &= 0.001084 \times 0.2 m + 0.46242 \times 0.8 m \\ m &= 135.08 \text{ kg} = 135 \text{ kg} \end{aligned}$$

End of Solution

Q.37 Consider an ideal vapour compression refrigeration cycle working on R-134a refrigerant. The COP of the cycle is 10 and the refrigeration capacity is 150 kJ/kg . The heat rejected by the refrigerant in the condenser is _____ kJ/kg (round off to the nearest integer).

Ans. (165)(165 to 165)

$$RE = 150 \text{ kJ/kg}$$

$$COP = 10$$

$$COP = \frac{Q_L}{W_{in}}$$

\Rightarrow

$$\begin{aligned} W_{in} &= 15 \text{ kJ/kg} \\ Q_H = Q_C &= Q_L + W_{in} \\ &= 150 + 15 \\ &= 165 \text{ kJ/kg} \end{aligned}$$

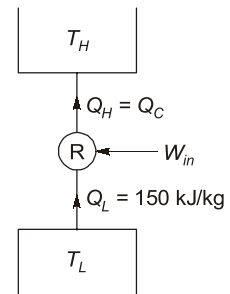

End of Solution

Q.38 The torque provided by an engine is given by $T(\theta) = 12000 + 2500 \sin(2\theta) \text{ N.m}$, where θ is the angle turned by the crank from inner dead center. The mean speed of the engine is 200 rpm and it drives a machine that provides a constant resisting torque. If variation of the speed from the mean speed is not to exceed $\pm 0.5\%$, the minimum mass moment of inertia of the flywheel should be _____ kg.m^2 (round off to the nearest integer).

Ans. (570)(560 to 580)

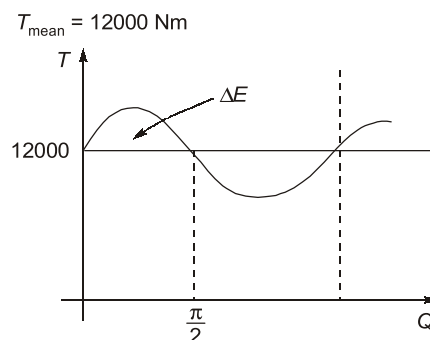

$$\omega = \frac{\pi \times 200}{30} = 20.9439 \text{ rad/s}$$

$$\Delta E = \int_0^{\frac{\pi}{2}} (T - T_{\text{mean}}) d\theta = 2500 \int_0^{\frac{\pi}{2}} \sin 2\theta d\theta$$

$$= 2500 \times 1 = 2500 \text{ J}$$

$$\Delta E = I\omega^2 C_s$$

$$2500 = I \times 20.9439^2 \times 0.01$$

⇒

$$I = 569.934 \text{ kgm}^2 \approx 570 \text{ kg.m}^2$$

End of Solution

Q.39 An object is moving with a Mach number of 0.6 in an ideal gas environment, which is at a temperature of 350 K. The gas constant is 320 J/kg.K and ratio of specific heats is 1.3. The speed of object is _____ m/s (round off to that nearest integer).

Ans. (229)(228 to 230)

$$M = \frac{V}{C} = \frac{V}{\sqrt{\gamma RT}}$$

$$0.6 = \frac{V}{\sqrt{1.3 \times 350 \times 320}}$$

$$V = 228.94 \text{ m/s} \approx 229 \text{ m/s}$$

End of Solution

Q.40 The machining process that involves ablation is

- (a) Laser Beam Machining (b) Abrasive Jet Machining
(c) Chemical Machining (d) Electrochemical Machining

Ans. (a)

End of Solution

Q.41 Water flows out from a large tank of cross-sectional area $A_t = 1 \text{ m}^2$ through a small rounded orifice of cross-sectional area $A_o = 1 \text{ cm}^2$, located at $y = 0$. Initially the water level (H), measured from $y = 0$, is 1 m. The acceleration due to gravity is 9.8 m/s^2 .

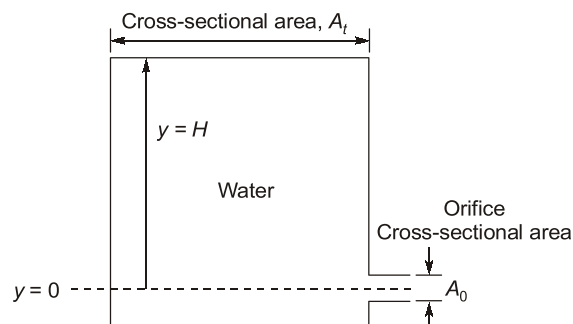

Neglecting any losses, the time taken by water in the tank to reach a level of $y = H/4$ is _____ seconds (round off to one decimal place).

Ans. (2258.8)(2257 to 2259)

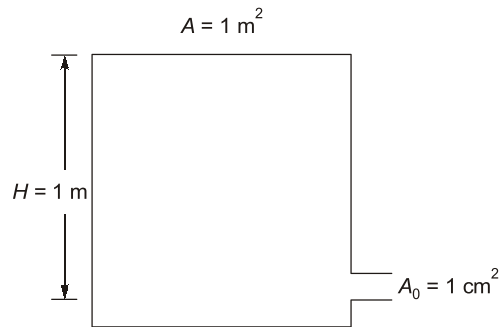

$$\dot{m}_{in} - \dot{m}_{out} = \frac{dm_w}{dt} \quad (\dot{m}_{in} = 0)$$

$$- \rho A_0 \sqrt{2gH} = \frac{d}{dt} [A \times H \times \rho]$$

$$dt = - \frac{A}{A_0} \times \frac{1}{\sqrt{2g}} \times \frac{dH}{\sqrt{H}}$$

$$t = - \frac{A}{A_0} \times \frac{1}{\sqrt{2g}} \int_1^{0.25} \frac{dH}{\sqrt{H}}$$

$$t = \frac{A}{A_0} \times \frac{1}{\sqrt{2g}} (2\sqrt{H})_{0.25}^1$$

$$t = \frac{1}{10^{-4}} (2-1) \times \frac{1}{\sqrt{2 \times 9.81}}$$

$$t = 2258.8 \text{ s}$$

End of Solution

Q.42 An adiabatic vortex tube, shown in the figure given below is supplied with 5 kg/s of air (inlet 1) at 500 kPa and 300 K. Two separate streams of air are leaving the device from outlets 2 and 3. Hot air leaves the device at a rate of 3 kg/s from outlet 2 at 100 kPa and 340 K, while 2 kg/s of cold air stream is leaving the device from outlet 3 at 100 kPa and 240 K.

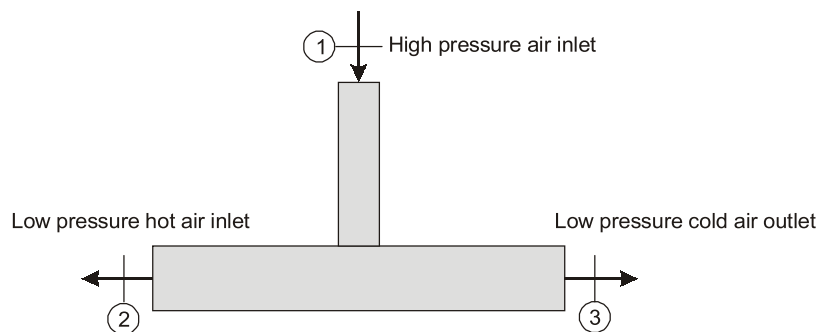

Consider constant specific heat of air is 1005 J/kg.K and gas constant is 287 J/kg.K. There is no work transfer across the boundary of this device. The rate of entropy generation is _____ kW/K (round off to one decimal place).

Ans. (2.2)(2.1 to 2.3)

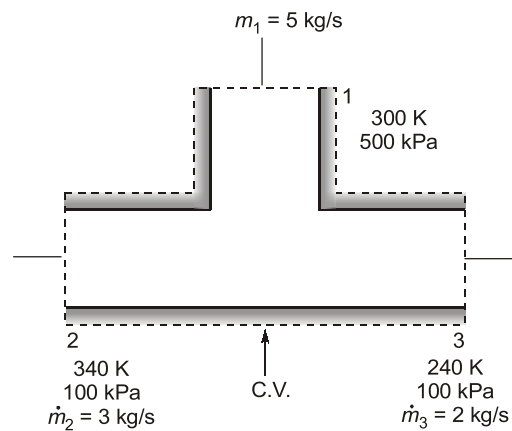

$$\left(\frac{dS}{dt}\right)_{C.V.} = \dot{S}_i + \dot{S}_{gen} - \dot{S}_e$$

$$\therefore \left(\frac{dS}{dt}\right)_{C.V.} = 0 \text{ [Steady state]}$$

$$\dot{S}_{gen} = \dot{S}_e - \dot{S}_i$$

$$= \underbrace{\dot{m}_2 s_2}_{\downarrow 3} + \underbrace{\dot{m}_3 s_3}_{\downarrow 2} - \underbrace{\dot{m}_1 s_1}_{\downarrow 5}$$

$$= 3(s_2 - s_1) + 2(s_3 - s_1)$$

$$= 3 \times 0.587 + 2(0.237)$$

$$= 2.235 \text{ kW/K} \approx 2.2 \text{ kW/K}$$

End of Solution

Q.43 A vertical shaft Francis turbine rotates at 300 rpm. The available head at the inlet to the turbine is 200 m. The tip speed of the rotor is 40 m/s. Water leaves the runner of the turbine without whirl. Velocity at the exit of the draft tube is 3.5 m/s. The head losses in different components of the turbine are: (i) stator and guide vanes: 5.0 m. (ii) rotor: 10 m, and (iii) draft tube: 2 m. Flow rate through the turbine is 20 m³/s. Take $g = 9.8 \text{ m/s}^2$. The hydraulic efficiency of the turbine is _____ % (round off to one decimal place).

Ans. 91.2 (90 to 92)

$$H_{inlet} = H_{turbine} + H_{L, \text{stator + Guide}} + H_{rotor} + H_{drafttube} + \frac{V_3^2}{2g}$$

$$200 = H_{turbine} + 5 + 10 + 2 + \frac{3.5^2}{2 \times 9.8}$$

$$H_{turbine} = 182.375 \text{ m}$$

$$\eta_H = \frac{H_{turbine}}{H_{inlet}} = \frac{182.375}{200} = 0.9118 = 91.187\%$$

End of Solution

Q.44 A power transmission mechanism consists of a belt drive and a gear train as shown in the figure.

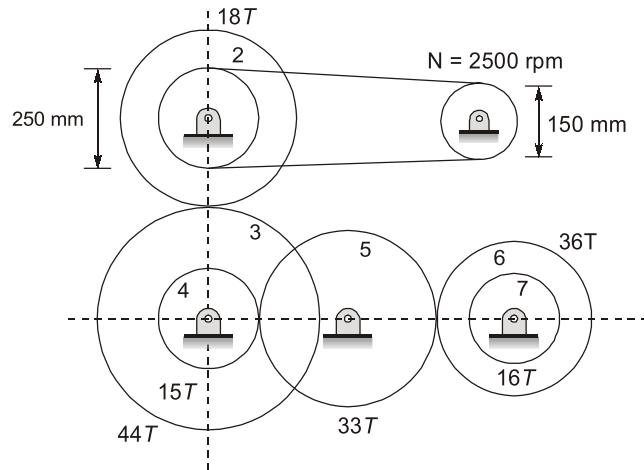

Diameters of pulleys of belt drive and number of teeth (T) on the gears 2 to 7 are indicated in the figure. The speed and direction of rotation of gear 7, respectively, are

- (a) 255.68 rpm; clockwise (b) 575.28 rpm; clockwise
 (c) 575.28 rpm; anticlockwise (d) 255.68 rpm; anticlockwise

Ans. (a)

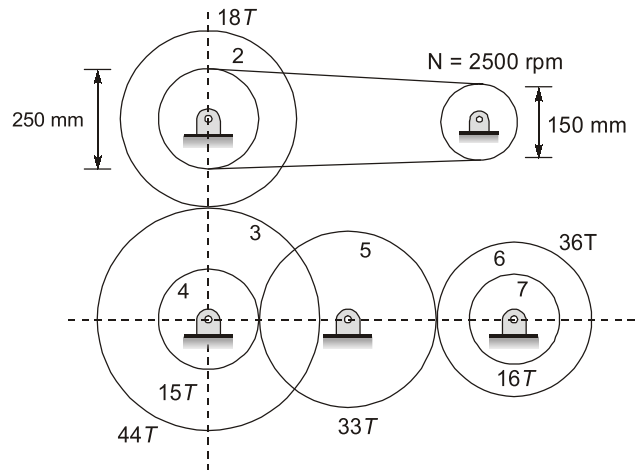

$$T_3 = 44$$

$$T_6 = 36$$

$$T_2 = 18$$

$$T_4 = 15$$

$$\frac{N_1}{N_0} = \frac{d_0}{d_1}$$

$$\Rightarrow N_1 = \frac{150}{250} \times 2500$$

$$N_1 = 15,00 = N_2$$

$$N_3 = \frac{N_2 \times T_2}{T_3} = \frac{1500 \times 18}{44} = 613.63636 = N_4$$

$$N_6 = \frac{N_4 \times T_4}{T_6} = \frac{613.63636 \times 15}{36} \\ = 255.6818 = N_7 \text{ (Clockwise)}$$

Gear 5 is idler.

End of Solution

Q.45 The value of $\int_0^{\pi/2} \int_0^{\cos\theta} r \sin\theta dr d\theta$ is

(a) 0

(b) $\frac{1}{6}$

(c) $\frac{4}{3}$

(d) π

Ans. (b)

$$I = \int_{\theta=0}^{\theta=\frac{\pi}{2}} \int_{r=0}^{r=\cos\theta} r \sin\theta dr d\theta$$

$$= \int_{\theta=0}^{\frac{\pi}{2}} \left[\frac{r^2}{2} \right]_0^{\cos\theta} \times \sin\theta d\theta$$

$$= \frac{1}{2} \int_{\theta}^{\frac{\pi}{2}} \sin\theta \cdot \cos^2\theta d\theta$$

Let, $\cos\theta = t$
 $-\sin\theta d\theta = dt$
 $\cos\theta = t$

at, $\theta = \frac{\pi}{2}; t = 0$
 $\theta = 0, t = 1$

$$= \int_1^0 \frac{-t^2}{2} dt$$

$$= \frac{-1}{2} \left[\frac{t^3}{3} \right]_1^0 = \frac{-1}{2} \times \left(\frac{-1}{3} \right)$$

$$= \frac{-1}{2} \left[\frac{-1}{3} \right] = \frac{1}{6}$$

End of Solution

- Q.46** In a CNC machine tool, the function of an interpolator is to generate
- (a) error signal for tool radius compensation during machining
 - (b) reference signal prescribing the shape of the part to be machined
 - (c) signal for the lubrication pump during machining
 - (d) NC code from the part drawing during post processing

Ans. (b)

In contouring systems the machining path is usually constructed from a combination of linear and circular segments. It is only necessary to specify the coordinates of the initial and final points of each segment, and the feed rate. The operation of producing the required shape based on this information is termed interpolation and the corresponding unit is the "interpolator". The interpolator coordinates the motion along the machine axes, which are separately driven, by providing reference positions instant by instant for the position-and velocity control loops, to generate the required machining path. Typical interpolators are capable of generating linear and circular paths.

End of Solution

- Q.47** Value of $(1 + i)^8$, where $i = \sqrt{-1}$, is equal to
- (a) $16i$
 - (b) 16
 - (c) $4i$
 - (d) 4

Ans. (b)

$$\begin{aligned} (1 + i)^8 \\ z = 1 + i \quad r = |z| = \sqrt{2} \\ \theta = \frac{\pi}{4} \\ (1 + i)^8 = \left(\sqrt{2}e^{i\frac{\pi}{4}}\right)^8 \\ = 16 \times e^{i \times 2\pi} \\ = 16(\cos 2\pi + i \sin 2\pi) \\ = 16 \times 1 = 16 \end{aligned}$$

End of Solution

- Q.48** Find the positive real root of $x^3 - x - 3 = 0$ using Newton-Raphson method. If the starting guess (x_0) is 2, the numerical value of the root after two iterations (x_2) is _____ (round off to two decimal places).

Ans. (1.67)(1.66 to 1.68)

Given, $f(x) = x^3 - x - 3, \quad x_0 = 2$
 $f'(x) = 3x^2 - 1$

Iteration 1: $x_1 = x_0 - \frac{f(x_0)}{f'(x_0)} = 2 - \frac{(8-2-3)}{3(4)-1} = 1.72$

Iteration 2: $x_2 = x_1 - \frac{f(x_1)}{f'(x_1)} = 1.72 - \frac{(1.72^3 - 1.72 - 3)}{3(1.72)^2 - 1} = 1.67$

End of Solution

Q.49 Consider an $n \times n$ matrix A and a non-zero $n \times 1$ vector p . Their product $Ap = \alpha^2 p$, where $\alpha \in \mathfrak{R}$ and $\alpha \notin \{-1, 0, 1\}$. Based on the given information, the eigen value of A^2 is:

- (a) $\sqrt{\alpha}$ (b) α^2
 (c) α (d) α^4

Ans. (d)

Given, $AP = \alpha^2 P$

By comparison with $AX = \lambda X$

$\Rightarrow \lambda = \alpha^2$

Hence, eigen value of A is α^2 , so eigen value of A^2 is α^4 .

End of Solution

Q.50 A high velocity water jet of cross section area = 0.01 m² and velocity = 35 m/s enters a pipe filled with stagnant water. The diameter of the pipe is 0.32 m. This high velocity water jet entrains additional water from the pipe and the total water leaves the pipe with a velocity 6 m/s as shown in the figure.

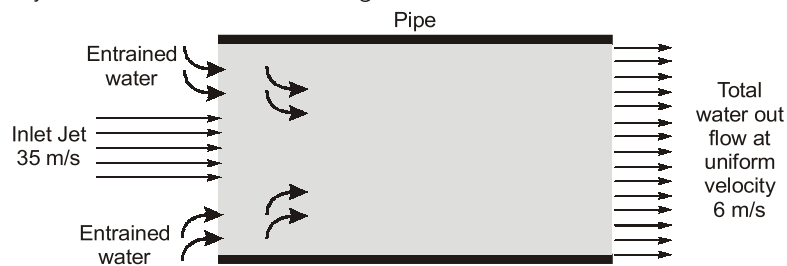

Ans. 132.55 (130 to 134)

Applying continuity equation :

$$35 \times 0.01 + \dot{q} = 6 \times \frac{\pi}{4} \times 0.32^2$$

$$\dot{q} = 0.13255 \text{ m}^3/\text{s}$$

$$\dot{q} = 132.55 \text{ l/s}$$

End of Solution

Q.51 The mean and variance, respectively, of a binomial distribution for n independent trials with the probability of success as p , are

- (a) $\sqrt{np}, \sqrt{np(1-p)}$ (b) $np, np(1-p)$
 (c) np, np (d) $\sqrt{np}, np(1-2p)$

Ans. (b)

$$\text{Mean} = np$$

$$\text{Variance} = npq = np(1-p)$$

End of Solution

Q.52 The thickness, width and length of a metal slab are 50 mm, 250 mm and 3600 mm, respectively. A rolling operation on this slab reduces the thickness by 10% and increases the width by 3%. The length of the rolled slab is _____ mm (round off to one decimal place).

Ans. (3883.5)(3880 to 3886)

$$h_1 = 50 \text{ mm}; \quad h_2 = 0.9h_1;$$

$$b_1 = 250 \text{ mm}; \quad b_2 = 1.03 b_1;$$

$$L_1 = 3600 \text{ mm}; \quad L_2 = ?$$

Volume remains constant in theory of plasticity

$$\begin{aligned} h_1 b_1 L_1 &= h_2 b_2 L_2 \\ &= 0.9h_1 \times 1.03b_1 \times L_2 \end{aligned}$$

$$L_2 = \frac{3600}{0.9 \times 1.03} = 3883.5 \text{ mm} = 3883.5 \text{ mm}$$

End of Solution

Q.53 The allowance provided in between a hole and a shaft is calculated from the difference between

- (a) upper limit of the shaft and the lower limit of the hole
- (b) lower limit of the shaft and the lower limit of the hole
- (c) upper limit of the shaft and the upper limit of the hole
- (d) lower limit of the shaft and the upper limit of the hole

Ans. (a)

It is minimum clearance or maximum interference. It is the intentional difference between the basic dimensions of the mating parts. The allowance may be positive or negative.

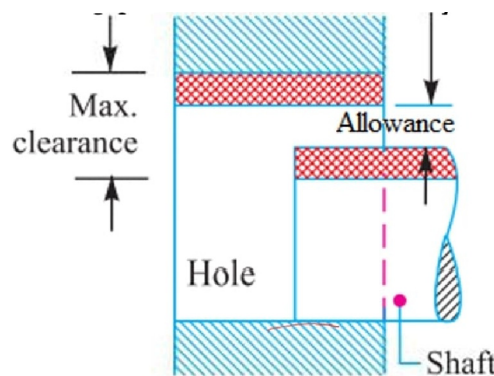

End of Solution

Q.54 A plane frame PQR (fixed at P and free at R) is shown in the figure. Both members (PQ and QR) have length, L , and flexural rigidity, EI . Neglecting the effect of axial stress and transverse shear, the horizontal deflection at free end, R , is

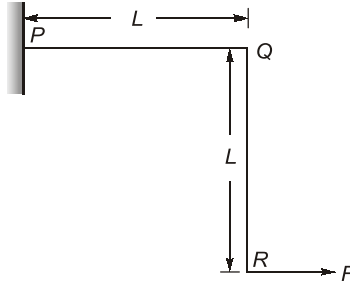

(a) $\frac{2FL^3}{3EI}$

(b) $\frac{4FL^3}{3EI}$

(c) $\frac{FL^3}{3EI}$

(d) $\frac{5FL^3}{3EI}$

Ans. (b)

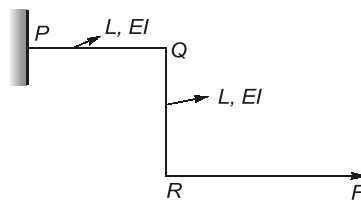

$$U = U_{PQ} + U_{QR}$$

$$U = \frac{M^2 L}{2EI} + \int_0^L \frac{(M_{x-x})^2}{2EI} (dx)$$

$$U = \frac{(FL)^2 L}{2EI} + \int_0^L \left(\frac{(Fx)^2}{2EI} \right)$$

$$U = \frac{F^2 L^3}{2EI} + \frac{F^2 L^3}{6EI} = \frac{2F^2 L^3}{3EI}$$

By Castigliano's theorem:

$$(\delta_H)_R = \frac{\partial U}{\partial F} = \frac{4FL^3}{3EI}$$

End of Solution

Q.55 Which of the following is responsible for eddy viscosity (or turbulent viscosity) in a turbulent boundary layer on a flat plate?

- (a) Nikuradse stresses (b) Boussinesq stresses
(c) Reynolds stresses (d) Prandtl stresses

Ans. (b)

End of Solution

