

GATE 2015 SOLVED PAPER ELECTRICAL ENGINEERING Set – I

Number of Questions: 65

Total marks: 100.0

Wrong answer for MCQ will result in negative marks, $(-1/3)$ for 1 Mark Questions and $(-2/3)$ for 2 Marks Questions.

GENERAL APTITUDE

Number of Questions: 10

Section Marks: 15.0

Q. 1 to Q. 5 carry 1 mark each and Q. 6 to Q. 10 carry 2 marks each

Question Number: 1 **Question Type: MCQ**

Out of the following four sentences, select the most suitable sentence with respect to grammar and usage:

- (A) Since the report lacked needed information, it was of no use to them.
- (B) The report was useless to them because there were no needed information in it.
- (C) Since the report did not contain the needed information, it was not real useful to them.
- (D) Since the report lacked needed information, it would not had been useful to them.

Solution: Option (A) is free of all errors. Though, the article 'the' before 'needed' would render it correct. But, of the given options, option (A) is correct. The use of 'there were' in option (B) is incorrect. 'Real useful' in ungrammatical in option (C). 'Not had been' is ungrammatical in option (D).

Hence, the correct option is (A).

Question Number: 2 **Question Type: MCQ**

In a triangle PQR , PS is the angle bisector of $\angle QPR$ and $\angle QPS = 60^\circ$. What is the length of PS ?

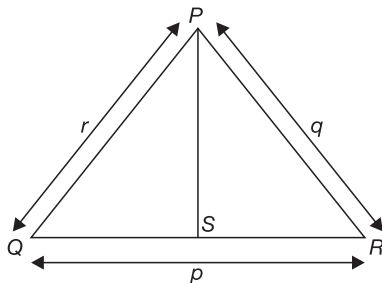

(A) $\frac{(q+r)}{qr}$

(B) $\frac{qr}{(q+r)}$

(C) $\sqrt{(q^2 + r^2)}$

(D) $\frac{(q+r)^2}{qr}$

Solution: Area of triangle

$$PQR = \text{Area of triangle } PQS$$

$$+ \text{Area of triangle } PSR$$

Area of triangle PQR

$$= \frac{1}{2}(r)(q) \sin \angle P$$

$$= \frac{1}{2}(r)(q) \sin (2\angle QPS)$$

$$= \frac{rq}{2} \sin 120^\circ$$

$$(\because PS \text{ is the angle bisector of } \angle QPR)$$

$$\therefore \frac{1}{2}(rq \sin 120^\circ)$$

$$= \frac{1}{2}[r(PS) \sin 60^\circ] + \frac{1}{2}[q(PS) \sin 60^\circ]$$

$$rq \left(\frac{\sqrt{3}}{2} \right) = (PS) \frac{\sqrt{3}}{2} (r+q)$$

$$PS = \frac{rq}{r+q}$$

Hence, the correct option is (B).

Question Number: 3

Question Type: NAT

If p, q, r, s are distinct integers such that:

$$f(p, q, r, s) = \max(p, q, r, s)$$

$$g(p, q, r, s) = \min(p, q, r, s)$$

$h(p, q, r, s) = \text{remainder of } (p \times q)/(r \times s)$
 if $(p \times q) > (r \times s)$
 or remainder of $(r \times s)/(p \times q)$ if $(r \times s) > (p \times q)$.

Also a function

$$fgh(p, q, r, s) = f(p, q, r, s) \times g(p, q, r, s) \times h(p, q, r, s).$$

Also the same operations are valid with two variable functions of the form $f(p, q)$.

What is the value of $fg[h(2, 5, 7, 3), 4, 6, 8]$?

Solution:

$$h(2, 5, 7, 3) = \text{remainder of } \left(\frac{21}{10}\right) = 1$$

$$[\because (r \times s) > (p \times q)]$$

$$\begin{aligned} fg[h(2, 5, 7, 3), 4, 6, 8] &= fg(1, 4, 6, 8) \\ &= f(1, 4, 6, 8) \times g(1, 4, 6, 8) \\ &= \max(1, 4, 6, 8) \times \min(1, 4, 6, 8) \\ &= 8 \times 1 = 8 \end{aligned}$$

Hence, the correct Answer is (8).

Question Number: 4 **Question Type: MCQ**

If the list of letters, P, R, S, T, U is an arithmetic sequence, which of the following are also in arithmetic sequence?

- I. $2P, 2R, 2S, 2T, 2U$
 - II. $P-3, R-3, S-3, T-3, U-3$
 - III. P^2, R^2, S^2, T^2, U^2
- (A) I only (B) I and II
 (C) II and III (D) I and III

Solution: P, R, S, T, U is an arithmetic sequence

$$\therefore R - P = S - R = T - S = U - T.$$

Let each of these equal values be k .

$$\begin{aligned} \text{I. } 2(R - P) &= 2(S - R) \\ &= 2(T - S) \\ &= 2(U - T) \\ &= 2k \end{aligned}$$

$\therefore 2P, 2R, 2S, 2T, 2U$ is an arithmetic sequence.

$$\begin{aligned} \text{II. } R - 3 - (P - 3) &= S - 3 - (R - 3) \\ &= T - 3 - (S - 3) \\ &= U - 3 - (T - 3) = k \end{aligned}$$

$\therefore P - 3, R - 3, S - 3, T - 3, U - 3$ is an arithmetic sequence.

Hence, the correct option is (B).

Question Number: 5 **Question Type: MCQ**

Four branches of a company are located at M, N, O and P . M is north of N at a distance of 4 km; P is south of O at a distance of 2 km; N is southeast of O by 1 km. What is the distance between M and P in km?

- (A) 5.34
- (B) 6.74
- (C) 28.5
- (D) 45.49

Solution: Line diagram:

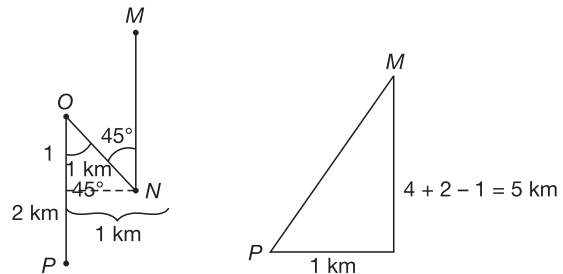

$$\begin{aligned} \text{So, } MP &= \sqrt{(5)^2 + (1)^2} = \sqrt{25 + 1} = \sqrt{26} \\ &= 5.34 \text{ kms} \end{aligned}$$

Hence, the correct option is (A).

Question Number: 6 **Question Type: MCQ**

We _____ our friend's birthday and we _____ how to make it up to him.

- (A) completely forgot—don't just know
- (B) forgot completely—don't just know
- (C) completely forgot—just don't know
- (D) forgot completely—just don't know

Solution: The correct answer is option (C). Here, 'completely' modifies 'forgot' which is to say that an action was missed out on. The same rule applies to the second blank as well. 'Don't know' come together, showing a misinformation and 'just' modifies it, showing an extent.

Hence, the correct option is (C).

Question Number: 7 **Question Type: MCQ**

Choose the statement where underlined word is used correctly.

- (A) The industrialist has a personnel jet.
- (B) I write my experience in my personnel dairy.
- (C) All personnel are being given the day off.
- (D) Being religious is a personnel aspect.

Solution: The word ‘personnel’ means a group of people who work for a company or an organization. Option (C) uses the word correctly. The rest of the options should use ‘personal’.

Hence, the correct option is (C).

Question Number: 8 Question Type: MCQ

A generic term that includes various items of clothing such as a skirt, a pair of trousers and a shirt is:

- (A) fabric (B) textile
- (C) fibre (D) apparel

Solution: The correct answer is option (D) apparel. Option (A) refers to the type of apparel. Option (B) refers to the business that makes apparels. Option (C) is again a material used to make an apparel.

Hence, the correct option is (D).

Question Number: 9 Question Type: MCQ

Based on the given statements, select the most appropriate option to solve the given question. What will be the total weight of 10 poles each of same weight?

Statements:

- I. One fourth of the weight of a pole is 5 kg.
- II. The total weight of these poles is 160 kg more than the total weight of two poles.

- (A) Statement I alone is not sufficient.
- (B) Statement II alone is not sufficient.
- (C) Either statement I or II alone is sufficient.
- (D) Both statements I and II together are not sufficient.

Solution:

I. Weight of the pole = 20 kg
Total weight of 10 poles = (20) (10) kg

Statement I is sufficient.

II. Total weight of 8 poles = 160 kg
Total weight of 10 poles = (160) kg

Statement II is sufficient.

Hence, the correct option is (C).

Question Number: 10 Question Type: MCQ

Consider a function $f(x) = 1 - |x|$ on $-1 \leq x \leq 1$. The value of x at which the function attains a maximum and the maximum value of the function are:

- (A) 0, -1 (B) -1, 0
- (C) 0, 1 (D) -1, 2

Solution: $f(x)$ is maximum when $|x|$ is minimum, i.e., when $|x|$ is zero i.e., when x is zero.

Maximum value of $f(x) = 1 - 0 = 1$. Which occurs at $x = 0$.

Hence, the correct option is (C).

ELECTRICAL ENGINEERING

Number of Questions: 55

Section Marks: 85.0

Q. 11 to Q. 35 carry 1 mark each and Q. 36 to Q. 65 carry 2 marks each

Question Number: 11 Question Type: MCQ

Find the transformer ratios a and b such that the impedance (Z_{in}) is resistive and equals 2.5Ω when the network is excited with a sine wave voltage of angular frequency of 5000 rad/s.

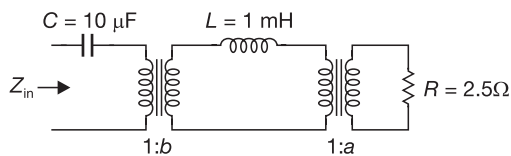

- (A) $a = 0.5, b = 2.0$
- (B) $a = 2.0, b = 0.5$
- (C) $a = 1.0, b = 1.0$
- (D) $a = 4.0, b = 0.5$

Solution:

$$Z_{in} = -jX_c + \frac{1}{b^2} \left[jX_L + \frac{1}{a^2} R \right]$$

$$Z_{in} = \frac{-j}{(5000 \times 10 \times 10^{-6})} + \frac{1}{b^2}$$

$$\left[j(5000)(10 \times 10^{-6}) + \frac{1}{a^2} (2.5) \right]$$

$$Z_{in} = -j20 + \frac{1}{b^2} \left[j5 + \frac{2.5}{a^2} \right]$$

For $Z_{in} = 2.5\Omega$
 $= 2.5\Omega$ (pure resistive)

$$-j20 + \frac{j5}{b^2} = 0 \text{ (reactance = 0)}$$

$$b^2 = \frac{1}{4} \text{ and } b = 0.5$$

$$Z_{in} = 2.5 \Omega = \frac{2.5}{a^2 b^2}$$

$$\Rightarrow a^2 b^2 = 1$$

$$a = \frac{1}{b} = 2$$

Hence, the correct option is (B).

Question Number: 12 **Question Type: NAT**

A shunt-connected DC motor operates at its rated terminal voltage. Its no-load speed is 200 radian/second. At its torque of 500 Nm, its speed is 180 radian/second. The motor is used to directly drive a load whose load torque T_L depends on its rotational speed ω_r (in radian/second), such that $T_L = 2.78 \times \omega_r$. Neglecting rotational losses, the steady-state speed (in radian/second) of the motor, when it drives this load, is _____.

Solution: At rated torque of 500 Nm with the relation

$$T_L = 2.78 \omega_r$$

$$\omega_r = \frac{T_L}{2.78} = \frac{500}{2.78} = 179.856 \text{ rad/sec}$$

Hence, the correct Answer is (177 to 183).

Question Number: 13 **Question Type: NAT**

The figure shows the per-phase equivalent circuit of a two-pole three-phase induction motor operating at 50 Hz. The 'air-gap' voltage, V_g across the magnetizing inductance, is 210 V rms, and the slip, s , is 0.05. The torque (in Nm) produced by the motor is _____.

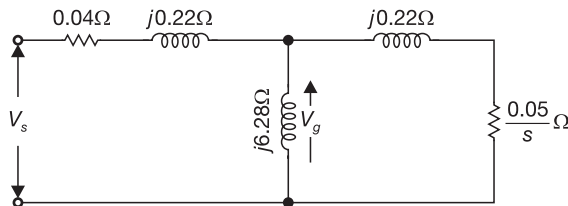

Solution: Rotor current I_2

$$= \frac{V_g}{\sqrt{\left(\frac{R_2}{S}\right)^2 + X_2^2}}$$

$$= \frac{210}{\sqrt{1^2 + 0.22^2}}$$

$$= 205.09 \text{ A}$$

Gross torque

$$= T_g$$

$$= \frac{3I_2^2 \frac{R_2(1S)}{S}}{\omega}$$

$$= \frac{3(205.09)^2 \times \frac{(0.05)(0.95)}{0.05}}{2\pi \times 2850}$$

$$60$$

$$T_g = 401.86 \text{ Nm}$$

Hence, the correct Answer is (400 to 403).

Question Number: 14 **Question Type: MCQ**

A 4-pole, separately excited, wave wound DC machine with negligible armature resistance is rated for 230 V and 5 kW at a speed of 1200 rpm. If the same armature coils are reconnected to form a lap winding, what is the rated voltage (in volts) and power (in kW), respectively at 1200 rpm of the reconnected machine if the field circuit is left unchanged?

- (A) 230 and 5
- (B) 115 and 5
- (C) 115 and 2.5
- (D) 230 and 2.5

Solution:

$$\text{Bode emf } E_b = \frac{\phi ZN}{60} \times \frac{P}{A}$$

$$E_b \propto \frac{1}{A}$$

$$\frac{E_{b_2}}{E_{b_1}} = \frac{A_1}{A_2}$$

$$\Rightarrow \frac{E_{b_2}}{230} = \frac{2(\text{wave winding})}{4(\text{lap winding})}$$

$$E_{b_2} = 115 \text{ V}$$

In wave winding $P = VI = 5 \text{ kW}$

Since number of parallel paths are doubled current also doubles in lap winding

$$P = \left(\frac{V}{2}\right)(2I) = 5 \text{ kW}$$

Hence, the correct option is (B).

Question Number: 15 **Question Type: NAT**

An open loop control system results in a response of $e^{-2t} (\sin 5t + \cos 5t)$ for a unit impulse input. The DC gain of the control system is _____.

Solution: Response

$$c(t) = e^{-2t} (\sin 5t + \cos 5t)$$

For unit impulse, gain

$$G(s) = \frac{C(s)}{R(s)}$$

$$= \frac{5}{(S+2)^2 + 5^2} + \frac{(S+2)}{(S+2)^2 + 5^2}$$

$$G(s) = \frac{S+7}{(S+2)^2 + 25}$$

DC gain

$$\lim_{s \rightarrow 0} G(s) = \lim_{s \rightarrow 0} \frac{S+7}{(S+2)^2 + 25}$$

$$= \frac{7}{4+25} = \frac{7}{29} = 0.241$$

Hence, the correct Answer is (0.23 to 0.25).

Question Number: 16 **Question Type: MCQ**

Nyquist plots of two functions $G_1(s)$ and $G_2(s)$ are shown in figure.

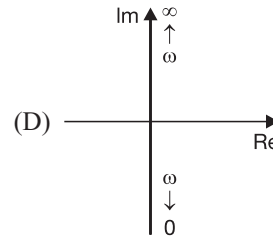
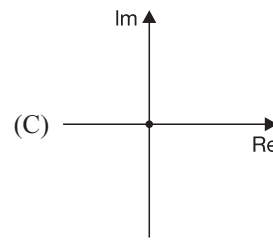
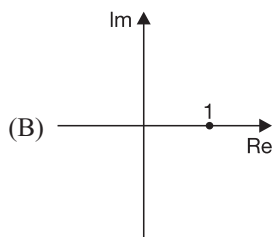
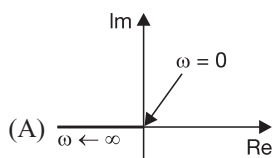
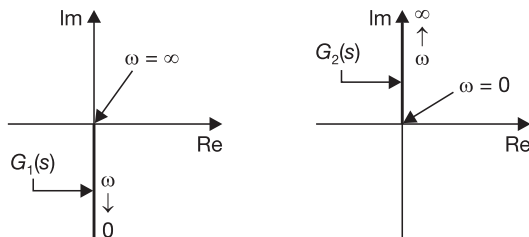

Solution: Nyquist product of $G_1(s)$ and $G_2(s)$

$$= \frac{1}{S} \times S = 1$$

Nyquist plot

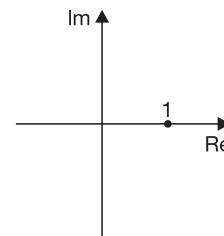

Hence, the correct option is (B).

Question Number: 17 **Question Type: NAT**

The volume enclosed by the surface $f(x, y) = e^x$ over the triangle bounded by the lines $x = y$; $x = 0$; $y = 1$ in the xy plane is _____.

Solution: The volume enclosed by the surface

$$f(x, y) = e^x$$

over the triangle OAB is

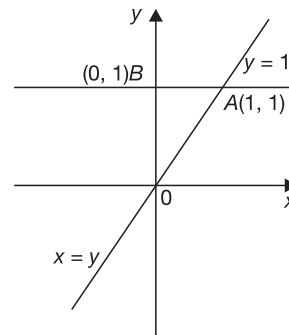

$$\begin{aligned}
 V &= \int_0^1 \int_0^y f(x, y) dx dy \\
 &= \int_0^1 \int_0^y e^x dx dy \\
 &= \int_0^1 \left(\int_0^y e^x dx \right) dy \\
 &= \int_0^1 \left[e^x \right]_{x=0}^y dy \\
 &= \int_0^1 [e^y - e^0] dy \\
 &= \int_0^1 (e^y - 1) dy \\
 &= e^y - y \Big|_0^1 \\
 &= (e^1 - 1) - (e^0 - 0) \\
 &= e - 2 \\
 &= 2.718 - 2 \\
 &= 0.718
 \end{aligned}$$

Hence, the correct Answer is (0.70 to 0.76).

Question Number: 18 **Question Type: MCQ**

Two coins R and S are tossed. The 4 joint events $H_R H_S$, $T_R T_S$, $H_R T_S$, $T_R H_S$ have probabilities 0.28, 0.18, 0.30, 0.24, respectively, where H represents head and T represents tail. Which one of the following is TRUE?

- (A) The coin tosses are independent.
- (B) R is fair, S is not.
- (C) S is fair, R is not.
- (D) The coin tosses are dependent.

Solution: When two coins R and S are tossed, given that the probabilities of the four joint events are $P(H_R H_S) = 0.28$, $P(T_R T_S) = 0.18$, $P(H_R T_S) = 0.30$ and $P(T_R H_S) = 0.24$.

Clearly, the coin tosses can't be independent

For, let $P(H_R) = r$ and $P(H_S) = s$
 $\Rightarrow P(T_R) = 1 - r$ and $P(T_S) = 1 - s$

If the coin tosses are independent, then

$$P(H_R H_S) = P(H_R) P(H_S) = 0.28$$

$$\Rightarrow rs = 0.28 \tag{1}$$

$$\Rightarrow P(T_R T_S) = P(T_R) P(T_S) = 0.18$$

$$\Rightarrow (1 - r)(1 - s) = 0.18 \tag{2}$$

$$\Rightarrow P(H_R T_S) = P(H_R) P(T_S) = 0.30$$

$$\Rightarrow r(1 - s) = 0.30 \tag{3}$$

$$\Rightarrow P(T_R H_S) = P(T_R) P(H_S) = 0.24$$

$$\Rightarrow (1 - r)s = 0.24 \tag{4}$$

$$\Rightarrow s - rs = 0.24$$

$$\Rightarrow s - 0.28 = 0.24 \Rightarrow s = 0.52$$

From Equation (3),

$$r - rs = 0.30$$

$$\Rightarrow r - 0.28 = 0.30 \Rightarrow r = 0.58$$

Substituting the values of r and s in Equation (2), we have

$$(1 - 0.58)(1 - 0.52) = 0.18$$

$$\Rightarrow (0.42)(0.48) = 0.18$$

$$0.2016 = 0.18 \text{ which is a absurd.}$$

Hence, the coin tosses are dependent.

Hence, the correct option is (D).

Question Number: 19 **Question Type: NAT**

A differential equation $\frac{di}{dt} - 0.2i = 0$ is applicable over $-10 < t \pm 10$. If $i(4) = 10$, then $i(-5)$ is _____.

Solution: Given differential equation is

$$\frac{di}{dt} - 0.2i = 0 \tag{1}$$

$$i(4) = 10 \tag{2}$$

From Equation (1),

$$\frac{di}{dt} = 0.2i \Rightarrow \frac{1}{i} di = 0.2dt$$

Integrating on both sides

$$\int \frac{1}{i} di = \int 0.2dt$$

$$\Rightarrow \ln i = 0.2t + c \Rightarrow i = e^{0.2t+c}$$

$$\Rightarrow i = c_1 e^{0.2t} \text{ where } c_1 = e^c$$

Given $i(4) = 10 \Rightarrow 10 = c_1 e^{0.2 \times 4}$

$$\Rightarrow c_1 e^{0.8} = 10 \Rightarrow c_1 = 10e^{-0.8}$$

Substituting the value of c_1 in Equation (3), we get

$$i = 10e^{-0.8} e^{0.2t}$$

$$i = 10e^{0.2t-0.8}$$

Now $i(-5) = 10e^{0.2 \times (-5) - 0.8} = 10e^{-1.8}$

$$= \frac{10}{e^{1.8}} = 1.653$$

Hence, the correct Answer is (1.6 to 1.7).

Question Number: 20 **Question Type: MCQ**

Consider a signal defined by

$$x(t) = \begin{cases} e^{j10t} & \text{for } |t| \leq 1 \\ 0 & \text{for } |t| > 1 \end{cases}$$

Its Fourier Transform is:

- (A) $\frac{2 \sin(\omega - 10)}{\omega - 10}$ (B) $2e^{j10} \frac{\sin(\omega - 10)}{\omega - 10}$
 (C) $\frac{2 \sin \omega}{\omega - 10}$ (D) $e^{j10\omega} \frac{2 \sin \omega}{\omega}$

Solution:

Given $x(t) = \begin{cases} e^{j10t} & \text{for } |t| \leq 1 \\ 0 & \text{for } |t| > 1 \end{cases}$

⇒ The Fourier Transform of $x(t)$ is

$$\begin{aligned} F[x(t)] &= \int_{-\infty}^{\infty} x(t) e^{-j\omega t} dt = \int_{-1}^1 e^{j10t} e^{-j\omega t} dt \\ &= \int_{-1}^1 e^{(10-\omega)jt} dt = \left[\frac{e^{(10-\omega)jt}}{(10-\omega)j} \right]_{-1}^1 \\ &= \frac{e^{(10-\omega)j}}{(10-\omega)j} - \frac{e^{-(10-\omega)j}}{(10-\omega)j} \\ &= \frac{2}{(10-\omega)} \left[\frac{e^{(10-\omega)j} - e^{-(10-\omega)j}}{2j} \right] \\ &= \frac{-2}{(\omega-10)} \left[\frac{e^{(\omega-10)j} - e^{-(\omega-10)j}}{2j} \right] \\ &= \frac{2}{(\omega-10)} \left[\frac{e^{(\omega-10)j} - e^{-(\omega-10)j}}{2j} \right] \\ &= \frac{2}{(\omega-10)} \sin(\omega-10). \end{aligned}$$

Hence, the correct option is (A).

Question Number: 21 **Question Type: NAT**

The coils of a wattmeter have resistances 0.01Ω and 1000Ω ; their inductances may be neglected. The wattmeter is connected as shown in the figure, to measure the power consumed by a load, which draws 25 A at power factor 0.8 . The voltage across the load terminals is 30 V . The percentage error on the wattmeter reading is _____.

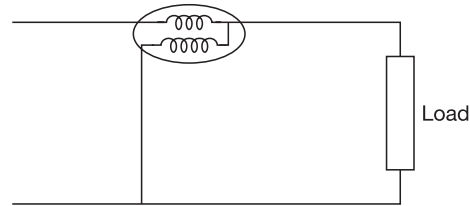

Solution:

Wattmeter error due to pressure coil

$$= \frac{V^2}{R} = \frac{30^2}{1000} = 0.9$$

Wattmeter reading = $VI \cos \theta$
 $= 30 \times 25 \times 0.8 = 600 \text{ W}$

$$\% \text{ error} = \frac{0.9}{600} \times 100 = 0.15\%$$

Hence, the correct Answer is (0.14 to 0.16).

Question Number: 22 **Question Type: NAT**

A buck converter feeding a variable resistive load is shown in the figure. The switching frequency of the switch S is 100 kHz and the duty ratio is 0.6 . The output voltage V_o is 36 V . Assume that all the components are ideal, and that the output voltage is ripple-free. The value of R (in Ohm) that will make the inductor current (i_L) just continuous is _____.

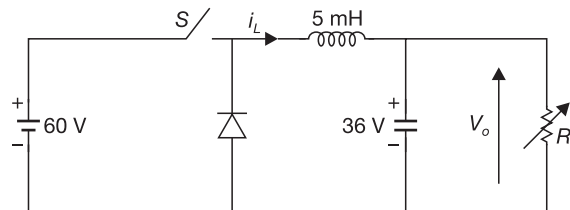

Solution: The inductor ripple current,

$$\begin{aligned} \Delta I &= \frac{V_o (V_s - V_o)}{fLV_s} \\ \Delta I &= \frac{36(60 - 36)}{100 \times 10^3 \times 5 \times 10^{-3} \times 60} \\ \Delta I &= 0.0288 \text{ A} \end{aligned}$$

The average inductor current,

$$\begin{aligned} I_L &= \frac{\Delta I}{2} = 0.0144 \text{ A} \\ I_L &= \frac{V_o}{R} = \frac{36}{R}; \quad R = 2500\Omega \end{aligned}$$

Hence, the correct Answer is (2480 to 2520).

Question Number: 23 **Question Type: NAT**

For the switching converter shown in the following figure, assume steady-state operation. Also assume that the components are ideal, the inductor current is always positive and continuous and switching period is T_s . If the voltage V_L is as shown, the duty cycle of the switch S is _____.

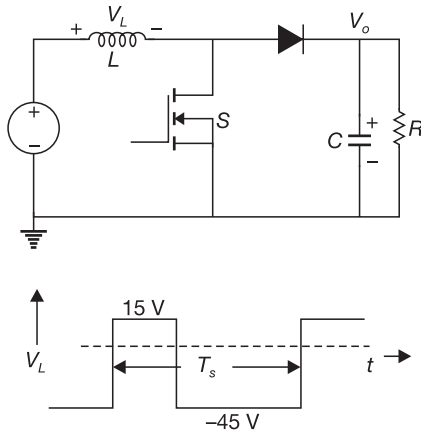

Solution: For continuous conduction, the average inductor voltage

$$V_L = 0$$

$$V_L = 15 \times \frac{T_{ON}}{T_S} + (-45) \frac{T_{OFF}}{T_S} = 0$$

$$15T_{ON} = 45T_{OFF}$$

$$\frac{T_{OFF}}{T_{ON}} = \frac{1}{3} \Rightarrow \frac{T_{OFF} + T_{ON}}{T_{ON}} = \frac{4}{3}$$

Duty ratio, $\delta = \frac{T_{ON}}{T} = 0.75$

Hence, the correct Answer is (0.75).

Question Number: 24 **Question Type: NAT**

In the given rectifier, the delay angle of the thyristor T_1 measured from the positive going zero crossing of V_s is 30° . If the input voltage V_s is $100 \sin(100\pi t)$ V, the average voltage across R (in Volt) under steady-state is _____.

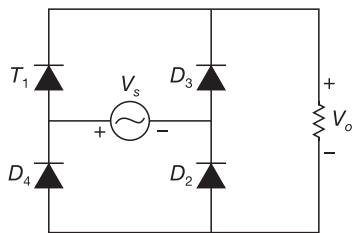

Solution: Average output voltage, $(V_o)_{avg}$

$$= \frac{1}{2\pi} \int_{-\infty}^{\pi} V_m \sin \omega t \, d\omega t$$

$$+ \frac{1}{2\pi} \int_{\pi}^{2\pi} -V_m \sin \omega t \, d\omega t$$

$$(V_o)_{avg} = \frac{V_m}{2\pi} [1 + \cos \alpha] - \frac{V_m}{2\pi} [\cos \pi - \cos 2\pi]$$

$$(V_o)_{avg} = \frac{V_m}{2\pi} (3 + \cos \alpha) = \frac{100}{2\pi} [3 + \cos 30]$$

$$(V_o)_{avg} = 61.56 \text{ V}$$

Hence, the correct Answer is (61 to 62).

Question Number: 25 **Question Type: MCQ**

For linear time invariant systems, that are Bounded Input Bounded Output stable, which one of the following statements is TRUE?

- (A) The impulse response will be integrable, but may not be absolutely integrable.
- (B) The unit impulse response will have finite support.
- (C) The unit step response will be absolutely integrable.
- (D) The unit step response will be bounded.

Solution: Unit step response will not be absolutely integrable but it will be bounded.

Hence, the correct option is (D).

Question Number: 26 **Question Type: MCQ**

The z-transform of a sequence $x[n]$ is given as $X(z) = 2z + 4 - 4/z + 3/z^2$. If $y[n]$ is the first difference of $x[n]$, then $Y(z)$ is given by

- (A) $2z + 2 - 8/z + 7/z^2 - 3/z^3$
- (B) $-2z + 2 - 6/z + 1/z^2 + 3/z^3$
- (C) $-2z - 2 + 8/z - 7/z^2 + 3/z^3$
- (D) $4z - 2 - 8/z - 1/z^2 + 3/z^3$

Solution:

$y(n)$ is first difference of

$$X(n) = x(n) - x(n-1)$$

$$Y(z) = X(z) - Z^{-1} X(z)$$

$$Y(z) = [2z + 4 - 4Z^{-1} + 3Z^{-2}] - [2 + 4z^{-1} - 4z^{-2} - 3z^{-3}]$$

$$Y(z) = 2z + 2 - \frac{8}{z} + \frac{7}{z^2} - \frac{3}{z^3}$$

Hence, the correct option is (A).

Question Number: 27 **Question Type: MCQ**

Two semi-infinite conducting sheets are placed at right angles to each other as shown in the figure. A point charge of $+Q$ is placed at a distance of d from both sheets. The net force on the charge is $\frac{Q^2}{4\pi\epsilon_0} \frac{K}{d^2}$ where K is given by:

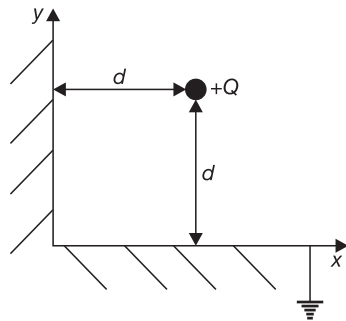

- (A) 0
- (B) $-\frac{1}{4}i - \frac{1}{4}j$
- (C) $-\frac{1}{8}i - \frac{1}{8}j$
- (D) $\frac{1-2\sqrt{2}}{8\sqrt{2}}i + \frac{1-2\sqrt{2}}{8\sqrt{2}}j$

Solution: The net force on the charge is

$$F = F_1$$

$$F = \frac{1}{4\pi\epsilon_0} \frac{Q^2}{(2d)^2} \left[-2da_x - 2da_y + \frac{1}{2\sqrt{2}}(2da_x + 2da_y) \right]$$

$$F = \frac{1}{4\pi\epsilon_0} \frac{Q^2}{d^2} \left[\frac{1-2\sqrt{2}}{8\sqrt{2}}a_x + \frac{1-2\sqrt{2}}{8\sqrt{2}}a_y \right]$$

$$F = \frac{1}{4\pi\epsilon_0} \cdot \frac{Q^2}{d^2} (k)$$

Hence, the correct option is (D).

Question Number: 28 **Question Type: MCQ**

In the following sequential circuit, the initial state (before the first clock pulse) of the circuit is $Q_1 Q_0 = 00$. The state $(Q_1 Q_0)$, immediately after the 333rd clock pulse is _____.

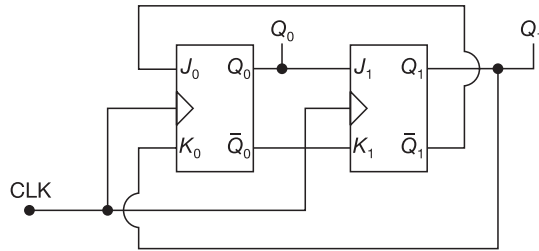

- (A) 00
- (B) 01
- (C) 10
- (D) 11

Solution: Johnson counter (MOD-4), number of cycles completed

$$= \frac{333}{4} = 83$$

Remainder clock is 1.

$J_1(Q_0)$	$K_1(\bar{Q}_0)$	$J_0(\bar{Q}_1)$	$K_0(Q_1)$	Q_1	Q_0
—	—	—	—	0	0
0	1	1	0	0	1
1	0	1	0	1	1
1	0	0	1	1	0
0	1	0	1	0	0

So, initial output at $Q_1 Q_0 = 00$, the next output is 01. Hence, the correct option is (B).

Question Number: 29 **Question Type: MCQ**

A Boolean function $f(A, B, C, D) = \prod (1, 5, 12, 15)$ is to be implemented using an 8×1 multiplexer (A is MSB). The inputs ABC are connected to the select inputs $S_2 S_1 S_0$ of the multiplexer, respectively.

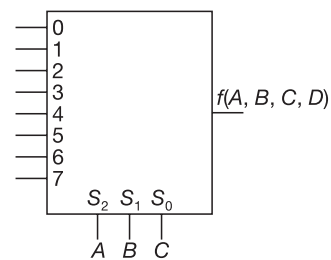

Which one of the following options gives the correct inputs to pins 0, 1, 2, 3, 4, 5, 6, 7 in order?

- (A) $D, 0, D, 0, 0, 0, \bar{D}, D$
- (B) $\bar{D}, 1, \bar{D}, 1, 1, 1, D, \bar{D}$
- (C) $D, 1, D, 1, 1, 1, \bar{D}, D$
- (D) $\bar{D}, 0, \bar{D}, 0, 0, 0, D, \bar{D}$

Solution: Boolean function

$$f(A, B, C, D) = \pi(1, 5, 12, 15)$$

The min term function

$$f(A, B, C, D) = \Sigma m(0, 2, 3, 4, 6, 7, 8, 9, 10, 11, 13, 14)$$

D	I ₀	I ₁	I ₂	I ₃	I ₄	I ₅	I ₆	I ₇
0	0	2	4	6	8	10	12	14
1	1	3	5	7	9	11	3	15
	\bar{D}	1	\bar{D}	1	1	1	D	\bar{D}

Hence, the correct option is (B).

Question Number: 30 **Question Type: MCQ**

The saturation voltage of the ideal op-amp shown below is ± 10 V. The output voltage v_0 of the following circuit in the steady-state is:

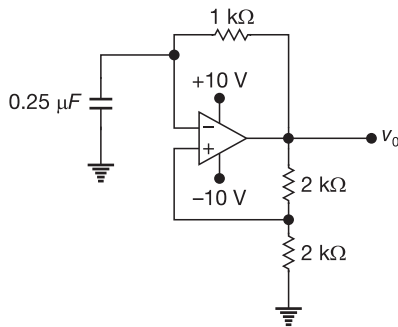

- (A) square wave of period 0.55 ms.
- (B) triangular wave of period 0.55 ms.
- (C) square wave of period 0.25 ms.
- (D) triangular wave of period 0.25 ms.

Solution:

$$\beta = \frac{R_2}{R_1 + R_2} = \frac{2}{4} = 0.5$$

Time period,

$$T = 2RC \log \left(\frac{1 + \beta}{1 - \beta} \right)$$

$$T = 2 \times 1 \times 10^3 \times 0.25 \times 10^{-6} \log \left(\frac{1 + 0.5}{1 - 0.5} \right)$$

$$T = 0.55 \text{ msec}$$

Astable multivibrator producer square wave with time period 0.55 msec.

Hence, the correct option is (A).

Question Number: 31 **Question Type: MCQ**

Given $f(z) = g(z) + h(z)$, where f, g, h are complex valued functions of a complex variable z . Which one of the following statements is TRUE?

- (A) If $f(z)$ is differentiable at z_0 , then $g(z)$ and $h(z)$ are also differentiable at z_0 .
- (B) If $g(z)$ and $h(z)$ are differentiable at z_0 , then $f(z)$ is also differentiable at z_0 .
- (C) If $f(z)$ is continuous at z_0 , then it is differentiable at z_0 .
- (D) If $f(z)$ is differentiable at z_0 , then so are its real and imaginary parts.

Solution: We know that every continuous function need NOT be differentiable

\therefore Option (C) is NOT TRUE

Counter Example for option (A):

Let $g(z) = 2x + i3y$ and $h(z) = 3x + i2y$

$$\begin{aligned} \Rightarrow f(z) &= g(z) + h(z) \\ &= (2x + i3y) + (3x + i2y) \\ &= 5x + i5y \\ &= 5(x + iy) \\ &= 5z, \text{ where } z = x + iy \end{aligned}$$

It can be easily observed that $g(z)$ and $h(z)$ does not satisfy Cauchy-Riemann equations.

But $f(z)$ is differentiable.

So, option (A) is NOT TRUE.

Option (D) is also NOT TRUE.

We know that the sum of two differentiable functions is always differentiable.

Hence, the correct option (B) is TRUE.

Question Number: 32 **Question Type: MCQ**

We have a set of 3 linear equations in 3 unknowns. ' $X \equiv Y$ ' means X and Y are equivalent statements and ' $X \not\equiv Y$ ' means X and Y are not equivalent statements.

- P. There is a unique solution.
- Q. The equations are linearly independent.
- R. All eigen values of the coefficient matrix are non-zero.
- S. The determinant of the coefficient matrix is non-zero.

Which one of the following is TRUE?

- (A) $P \equiv Q \equiv R \equiv S$
- (B) $P \equiv R \not\equiv Q \equiv S$
- (C) $P \equiv Q \not\equiv R \equiv S$
- (D) $P \not\equiv Q \not\equiv R \not\equiv S$

Solution: All the four statements P, Q, R and S are equivalent.

Hence, the correct option is (A).

Question Number: 33

Question Type: MCQ

Match the following:

- P. Stoke's Theorem 1. $\oiint D \cdot ds = Q$
 Q. Gauss's Theorem 2. $\oint f(z) dz = 0$
 R. Divergence Theorem 3. $\iiint (\nabla \cdot A) dv = \oiint A \cdot ds$
 S. Cauchy's Integral Theorem 4. $\iint (\nabla \times A) \cdot ds = \oint A \cdot dl$

- (A) P-2 Q-1 R-1 S-3
 (B) P-4 Q-1 R-3 S-2
 (C) P-4 Q-3 R-1 S-2
 (D) P-3 Q-4 R-2 S-1

Solution: Correct matching is P-4, Q-1, R-3, S-2.

Hence, the correct option is (B).

Question Number: 34

Question Type: MCQ

The Laplace transform of $f(t) = 2\sqrt{t/\pi}$ is $s^{-3/2}$. The Laplace transform of $g(t) = \sqrt{1/\pi t}$ is:

- (A) $3s^{-5/2}/2$
 (B) $s^{-1/2}$
 (C) $s^{1/2}$
 (D) $s^{3/2}$

Solution:

Given $f(t) = 2\sqrt{\frac{t}{\pi}}$ and $L[f(t)] = s^{-3/2}$

$$\Rightarrow f^1(t) = 2 \cdot \frac{1}{2\sqrt{t}} \cdot \frac{1}{\sqrt{\pi}} = \frac{1}{\sqrt{\pi t}} = \sqrt{\frac{1}{\pi t}}$$

$\therefore f^1(t) = g(t)$

We know that

$$L[f^1(t)] = sL[f(t)] - f(0)$$

$$\therefore L[g(t)] = L\left[\sqrt{\frac{1}{\pi t}}\right] = L[f^1(t)]$$

$$= s\left(s^{-3/2}\right) - 2\sqrt{\frac{0}{\pi}}$$

$$= s^{-1/2} - 0 = s^{-1/2}$$

Hence, the correct option is (B).

Question Number: 35

Question Type: MCQ

Match the following:

Instrument Type	Used for
P. Permanent magnet moving coil	1. DC only
Q. Moving iron connected through current transformer	2. AC only
R. Rectifier	3. AC and DC
S. Electrodynamometer	

- (A) P-1 Q-2 R-1 S-3
 (B) P-1 Q-3 R-1 S-2
 (C) P-1 Q-2 R-3 S-3
 (D) P-3 Q-1 R-2 S-1

Solution: PMMC meter can show deflection for only dc and for ac average torque produced will be zero. Moving iron instrument along with CT can be used only for AC. Rectifier instrument converter AC to DC and can be used for both AC and DC.

Hence, the correct option is (C).

Question Number: 36

Question Type: MCQ

A three-phase balanced load which has a power factor of 0.707 is connected to a balanced supply. The power consumed by the load is 5 kW. The power is measured by the two-wattmeter method. The readings of the two wattmeters are:

- (A) 3.94 kW and 1.06 kW
 (B) 2.50 kW and 2.50 kW
 (C) 5.00 kW and 0.00 kW
 (D) 2.96 kW and 2.04 kW

Solution:

Total power consumed

$$W_1 + W_2 = 5 \text{ kW} \tag{1}$$

Power factor = $\cos \phi = \cos 45^\circ = 0.707$

$$\frac{\pi}{4} = \phi = \tan^{-1} \left[\frac{\sqrt{3}(W_1 - W_2)}{W_1 + W_2} \right]$$

$$W_1 - W_2 = \frac{5}{\sqrt{3}} \tag{2}$$

Solving Equations (1) and (2)

$$W_1 = 3.94 \text{ kW}$$

and $W_2 = 1.06 \text{ kW}$

Hence, the correct option is (A).

Question Number: 37 **Question Type: NAT**

A capacitive voltage divider is used to measure the bus voltage V_{bus} in a high-voltage 50 Hz AC system as shown in the figure. The measurement capacitors C_1 and C_2 have tolerances of $\pm 10\%$ on their nominal capacitance values. If the bus voltage V_{bus} is 100 kV rms, the maximum rms output voltage V_{out} (in kV), considering the capacitor tolerance, is _____.

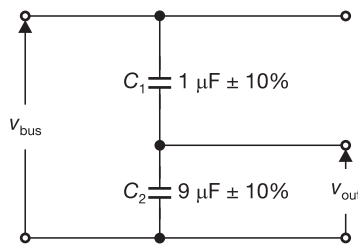

Solution:

$$V_{out} = V_{bus} \times \frac{C_1}{C_1 + C_2}$$

For maximum

$$\begin{aligned} V_{out} &= 100 \times \frac{(1 + 10\%)}{(1 + 10\%) + (9 - 10\%)} \\ &= 100 \times \frac{1.1}{(1.1 + 8.1)} = 11.95 \text{ kV} \end{aligned}$$

Hence, the correct Answer is (11.75 to 12.25).

Question Number: 38 **Question Type: MCQ**

In the following circuit, the input voltage V_{in} is $100 \sin(100\pi t)$. For $100\pi RC = 50$, the average voltage across R (in Volts) under steady-state is nearest to:

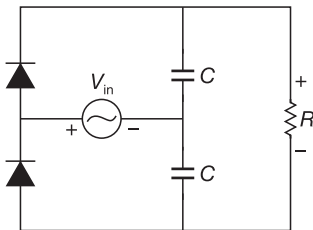

- (A) 100
- (B) 31.8
- (C) 200
- (D) 63.6

Solution: During positive half cycle of the supply under steady-state.

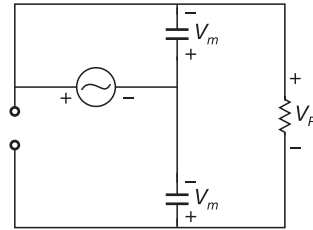

During negative half cycle of the supply under steady-state.

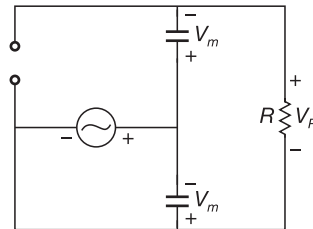

$$\begin{aligned} \text{Average voltage across resistance } |(V_R)_{avg}| \\ = 200 \text{ V} \end{aligned}$$

Hence, the correct option is (C).

Question Number: 39 **Question Type: MCQ**

Two semi-infinite dielectric regions are separated by a plane boundary at $y = 0$. The dielectric constants of region 1 ($y < 0$) and region 2 ($y > 0$) are 2 and 5, respectively. Region 1 has uniform electric field $E = 3\hat{a}_y + 2\hat{a}_z$, where \hat{a}_x , \hat{a}_y and \hat{a}_z are unit vectors along the x , y and z axes, respectively. The electric field in region 2 is:

- (A) $3\hat{a}_x + 1.6\hat{a}_y + 2\hat{a}_z$
- (B) $1.2\hat{a}_x + 4\hat{a}_y + 2\hat{a}_z$
- (C) $1.2\hat{a}_x + 4\hat{a}_y + 0.8\hat{a}_z$
- (D) $3\hat{a}_x + 10\hat{a}_y + 0.8\hat{a}_z$

Solution: The electric field in region 1 is

$$E_1 = 3a_x + 4a_y + 2a_z$$

The electric field in region 2 is

$$E_2 = 3a_x + \frac{2}{4}(4a_y) + 2a_z$$

$$E_2 = 3a_x + 1.6a_y + 2a_z$$

Hence, the correct option is (A).

Question Number: 40 **Question Type: NAT**

A circular turn of radius 1 m revolves at 60 rpm about its diameter aligned with the x -axis as shown in the figure. The value of μ_0 is $4\pi \times 10^{-7}$ in SI unit. If a

uniform magnetic field intensity $\vec{H} = 10^7 \hat{z}$ A/m is applied, then the peak value of the induced voltage, V_{turn} (in Volts), is _____.

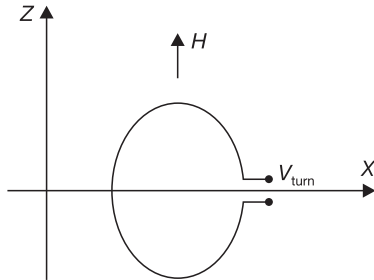

Solution: Magnetic flux density by,

$$B = \mu_o H = 4\pi \times 10^{-7} \times 10^7 \hat{a}_z = 4\pi \hat{a}_z$$

Flux, $\phi = BA = 4\pi \times \pi r^2 \sin \omega t$

$$V = \frac{-d\phi}{dt} = 4\pi^2 r^2 (-\cos \omega t) \omega$$

$$|V| = 4\pi^2 r^2 \omega = 4\pi^2 r^2 \frac{2\pi N}{60}$$

$$= 4\pi^2 \times 1^2 \times \frac{2\pi \times 60}{60}$$

$$= 8\pi^2 = 248.05 \text{ V}$$

Hence, the correct Answer is (246 to 250).

Question Number: 41 **Question Type: NAT**

The operational amplifier shown in the figure is ideal. The input voltage (in Volt) is $V_i = 2 \sin(2\pi \times 2000t)$. The amplitude of the output voltage V_o (in Volt) is _____.

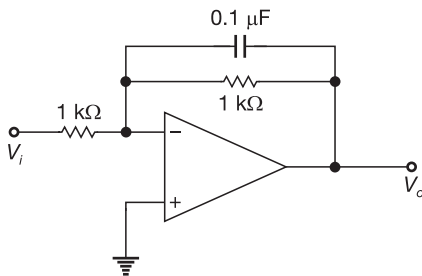

Solution: Output voltage of inverting amplifier

$$V_o = V_i \times \frac{(-Z_2)}{Z_1}$$

$$Z_1 = 1 \times 10^2 \Omega$$

$$Z_2 = \frac{(1 \times 10^3) \frac{1}{(0.1 \times 10^{-6} S)}}{10^3 + \frac{1}{(0.1 \times 10^{-6} S)}}$$

$$= \frac{10^3}{1 + j0.1 \times 10^3 \omega}$$

for $\omega = 2\pi \times 2000$ rad/sec

$$Z_2 = \frac{10^3}{1 + j0.4\pi}$$

and $|Z_2| = \frac{10^3}{\sqrt{1 + (0.4\pi)^2}} = \frac{10^3}{1.6}$

$$|V_o| = 2 \times \frac{\left(\frac{10^3}{1.6}\right)}{1 \times 10^3} = \frac{2}{1.6} \cong 1.25$$

Hence, the correct Answer is (1.1 to 1.4).

Question Number: 42 **Question Type: NAT**

The following circuit, the transistor is in active mode and $V_C = 2$ V. To get $V_C = 4$ V, we replace R_C with R_C^1 . Then the ratio R_C^1/R_C is _____.

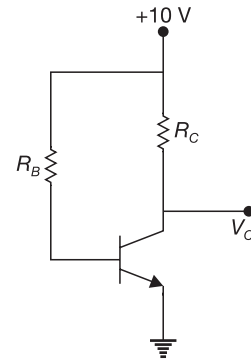

Solution:

For $V_C = 2$ V, $R_C = \frac{10 - V_C}{I_C} = \frac{10 - 2}{I_C}$ (1)

For $V_C = 4$ V, $R_C^1 = \frac{10 - V_C}{I_C} = \frac{10 - 4}{I_C}$ (2)

$$\frac{(2)}{(1)} = \frac{R_C^1}{R_C} = \frac{6}{8} = 0.75$$

Hence, the correct Answer is (0.74 to 0.76).

Question Number: 43 **Question Type: MCQ**

Consider the following sum of products expression, F .

$$F = ABC + \bar{A}\bar{B}C + A\bar{B}C + \bar{A}BC + \bar{A}\bar{B}\bar{C}$$

The equivalent product of sums expression is

- (A) $F = (A + \bar{B} + C)(\bar{A} + B + C)(\bar{A} + \bar{B} + C)$
- (B) $F = (A + \bar{B} + \bar{C})(A + B + C)(\bar{A} + \bar{B} + \bar{C})$
- (C) $F = (\bar{A} + \bar{B} + \bar{C})(A + \bar{B} + \bar{C})(A + B + C)$
- (D) $F = (\bar{A} + \bar{B} + C)(A + B + \bar{C})(A + B + C)$

Solution: K-map for the expression

$$F = ABC + \bar{A}\bar{B}C + A\bar{B}C + \bar{A}BC + \bar{A}\bar{B}\bar{C}$$

The equivalent POS form is

$$= (\bar{A} + \bar{B} + C)(\bar{A} + B + C)(A + \bar{B} + C)$$

	BC				
A					

Hence, the correct option is (A).

Question Number: 44 **Question Type: MCQ**

The filters F_1 and F_2 having characteristics as shown in Figures (a) and (b) are connected as shown in Figure (c).

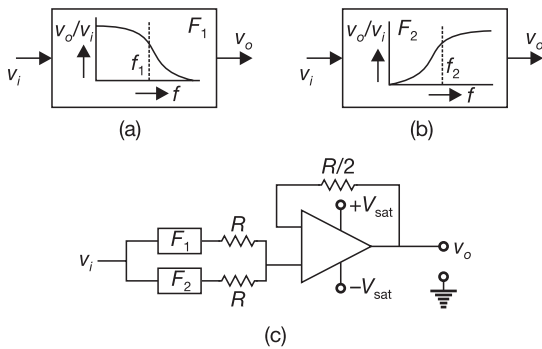

The cut-off frequencies of F_1 and F_2 are f_1 and f_2 , respectively. If $f_1 < f_2$, the resultant circuit exhibits the characteristics of a:

- (A) band-pass filter
- (B) band-stop filter
- (C) all pass filter
- (D) high-Q filter

Solution: Filter F_1 is a low pass filter and filter F_2 is high pass filter and addition of two filters gives band stop filter ($f_1 < f_2$).

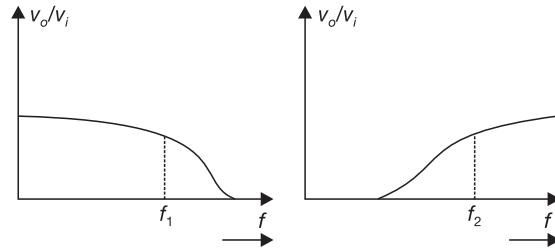

Hence, the correct option is (B).

Question Number: 45 **Question Type: MCQ**

When a bipolar junction transistor is operating in the saturation mode, which one of the following statements is TRUE about the state of its collector-base (CB) and the base-emitter (BE) junctions?

- (A) The CB junction is forward biased and the BE junction is reverse biased.
- (B) The CB junction is reverse biased and the BE junction is forward biased.
- (C) Both the CB and BE junctions are forward biased.
- (D) Both the CB and BE junctions are reverse biased.

Solution: BJT operates in saturation mode when both the junctions are in forward biased mode, operates in cut-off mode when both the junctions are in reverse biased mode and active mode when one of the junction in forward biased mode and other one in reverse biased mode.

Hence, the correct option is (C).

Question Number: 46 **Question Type: MCQ**

The synchronous generator shown in the figure is supplying active power to an infinite bus via two short, lossless transmission lines, and is initially in steady-state. The mechanical power input to the generator and the voltage magnitude E are constant. If one line is tripped at time t_1 by opening the circuit breakers at the two ends (although there is no fault), then it is seen that the generator undergoes a stable transient. Which one of the following waveforms of the rotor angle δ shows the transient correctly?

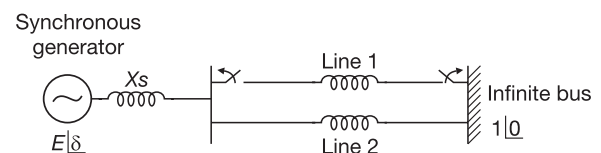

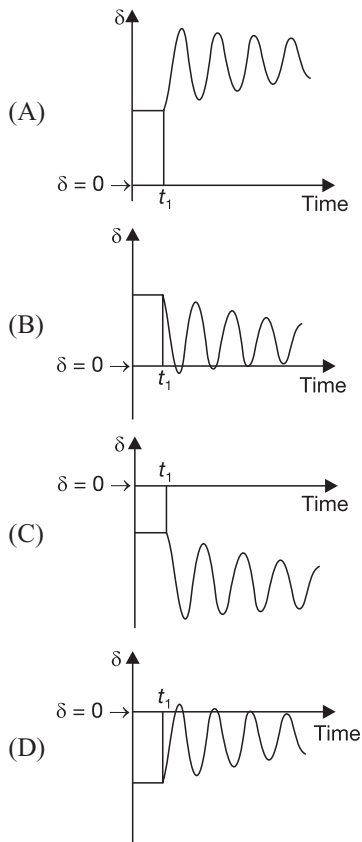

Solution: For alternator rotor angle is positive, after fault occurring this rotor angle increases.

Hence, the correct option is (A).

Question Number: 47 **Question Type: MCQ**

A 3-bus power system network consists of 3 transmission lines. The bus admittance matrix of the uncompensated system is

$$\begin{bmatrix} -j6 & j3 & j4 \\ j3 & -j7 & j5 \\ j4 & j5 & -j8 \end{bmatrix} \text{ pu.}$$

If the shunt capacitance of all transmission lines is 50% compensated, the imaginary part of the 3rd row 3rd column element (in pu) of the bus admittance matrix after compensation is:

- (A) $-j7.0$ (B) $-j8.5$
 (C) $-j7.5$ (D) $-j9.0$

Solution:

$$Y_{\text{Bus}} = \begin{bmatrix} y_{11} & -y_{12} & -y_{13} \\ -y_{21} & y_{22} & -y_{23} \\ -y_{31} & -y_{32} & y_{33} \end{bmatrix}$$

$$\begin{aligned} y_{33} &= -j8 = y_{30} + y_{31} + y_{32} \\ -j8 &= y_{30} + (-j4) + (-j5) \\ y_{30} &= j1 \end{aligned}$$

Compensation of $y_{30} = \frac{j1}{2} = j0.5$

$$y_{33(\text{new})} = j0.5 - j4 - j5 = -j8.5$$

Hence, the correct option is (B).

Question Number: 48 **Question Type: MCQ**

A series RL circuit is excited at $t = 0$ by closing a switch as shown in the figure. Assuming zero initial conditions, the value of $\frac{d^2i}{dt^2}$ at $t = 0^+$ is

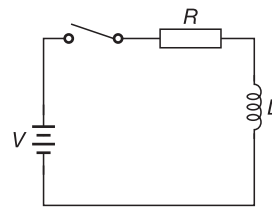

- (A) $\frac{V}{L}$ (B) $\frac{-V}{R}$
 (C) 0 (D) $\frac{-RV}{L^2}$

Solution:

By applying KVL: $V = iR + L \frac{di}{dt}$

By solving above equation:

$$i(t) = \frac{V}{R}(1 - e^{-t/\tau})$$

Differentially above equation,

$$\frac{di(t)}{dt} = \frac{V}{R} \times \frac{1}{\tau} e^{-t/\tau} = \frac{V}{L} e^{-t/\tau}$$

and 2nd order differentially,

$$\begin{aligned} \frac{d^2i(t)}{dt^2} &= \frac{-V}{L} \times \frac{1}{\tau} e^{-t/\tau} \\ &= \frac{-VR}{L^2} e^{-t/\tau} \end{aligned}$$

$$\left. \frac{d^2i(t)}{dt^2} \right|_{t=0} = \frac{-VR}{L^2}$$

Hence, the correct option is (D).

Question Number: 49 **Question Type: NAT**

The current i (Ampere) in the 2Ω resistor of the given network is _____.

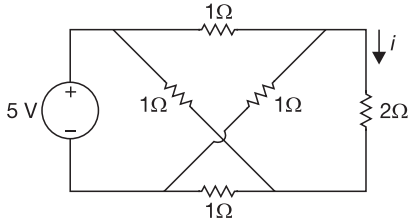

Solution: The network can be redrawn as

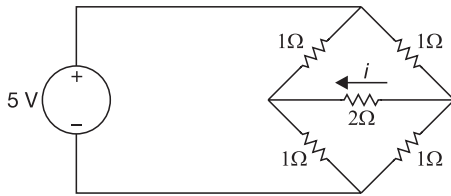

For balanced bridge $i = 0$ A.

Question Number: 50 **Question Type: NAT**

The incremental costs (in Rupees/MW/h) of operating two generating units are functions of their positive powers P_1 and P_2 in MW, and are given by

$$\frac{dC_1}{dP_1} = 0.2P_1 + 50$$

$$\frac{dC_2}{dP_2} = 0.24P_2 + 40$$

where

$$20 \text{ MW} \leq P_1 \leq 150 \text{ MW}$$

$$20 \text{ MW} \leq P_2 \leq 150 \text{ MW}$$

For a certain load demand, P_1 and P_2 have been chosen such that $dC_1/dP_1 = 76$ Rupees/MW/h and $dC_2/dP_2 = 68.8$ Rupees/MW/h. If the generations are rescheduled to minimize the total cost, then P_2 is _____.

Solution: The incremental fuel cost equations are

$$\frac{dC_1}{dP_1} = 76 = 0.2P_1 + 50 \Rightarrow P_1 = 120$$

$$\frac{dC_2}{dP_2} = 68.8 = 0.24P_2 + 40$$

$$\Rightarrow P_2 = 130$$

$$\text{and } P_1 + P_2 = 250$$

For the total cost minimization

$$\lambda = \frac{dC_1}{dP_1} = \frac{dC_2}{dP_2}$$

$$0.2P_1 + 50 = 0.24P_2 + 40 \quad (2)$$

$$0.2(250 - P_2) + 50 = 0.24P_2 + 40$$

$$P_2 = 136.36 \text{ MW}$$

Hence, the correct Answer is (135 to 137).

Question Number: 51 **Question Type: NAT**

A composite conductor consists of three conductors of radius R each. The conductors are arranged as shown below. The geometric mean radius (GMR) (in cm) of the composite conductor is kR . The value of k is _____.

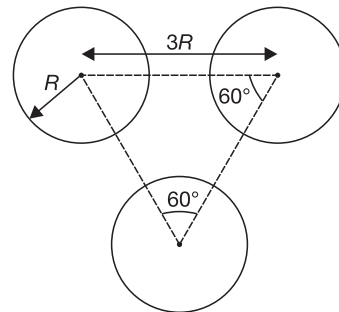

Solution: For symmetrical spacing,

$$\text{GMR} = \sqrt{\text{GMR}_1 \text{GMR}_2 \text{GMR}_3}$$

$$\text{GMR} = \text{GMR}_1 = \sqrt[3]{0.7788R \times 3R \times 3R}$$

$$\text{GMR} = KR = (\sqrt[3]{0.7788 \times 3 \times 3}) R$$

$$K = 1.913$$

Hence, the correct Answer is (1.85 to 1.95).

Question Number: 52 **Question Type: MCQ**

A 3-k phase transformer rated for 33 kV/11 kV is connected in delta/star as shown in figure. The current transformers (CTs) on low and high voltage sides have a ratio of 500/5. Find the currents i_1 and i_2 , if the fault current is 300 A as shown in figure.

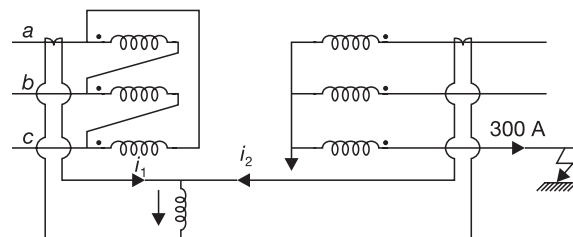

(1)

- (A) $i_1 = 1/\sqrt{3}$ A, $i_2 = 0$ A
- (B) $i_1 = 0$ A, $i_2 = 0$ A
- (C) $i_1 = 0$ A, $i_2 = 1/\sqrt{3}$ A
- (D) $i_1 = 1/\sqrt{3}$ A, $i_2 = 1/\sqrt{3}$ A

Solution: Since fault occurred on secondary side and outside of the CT connected winding, $i_2 = 0$ A.

Current through secondary of the transforms

$$I_s = 300 \times \frac{5}{500} = 3 \text{ A}$$

Current through primary of the transformer

$$= I_p = 3 \times \frac{11}{33} = 1 \text{ A}$$

Phase current $I_{ph} = \frac{I_p}{\sqrt{3}}$

$$i_1 = I_{ph} = \frac{1}{\sqrt{3}} \text{ A}$$

Hence, the correct option is (A).

Question Number: 53 **Question Type: MCQ**

A balanced (positive sequence) three-phase AC voltage source is connected to a balanced, star connected load through a star-delta transformer as shown in the figure. The line-to-line voltage rating is 230 V on the star side, and 115 V on the delta side. If the magnetizing current is neglected and $\bar{I}_s = 100 \angle 0^\circ$ A, then what is the value of \bar{I}_p in Ampere?

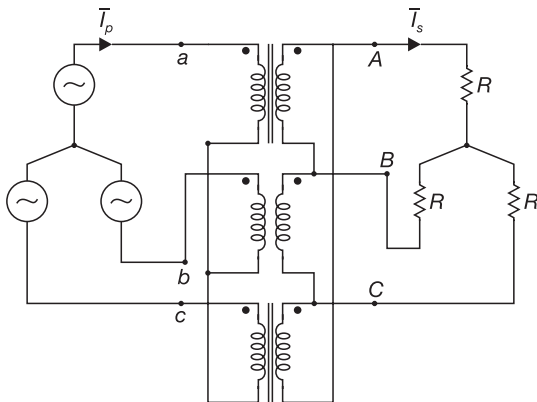

- (A) $50 \angle 30^\circ$
- (B) $50 \angle -30^\circ$
- (C) $50\sqrt{3} \angle 30^\circ$
- (D) $200 \angle 30^\circ$

Solution: In transformer

$$(\text{KVA})_{\text{primary}} = (\text{KVA})_{\text{secondary}}$$

$$\sqrt{3}V_p I_p = \sqrt{3}V_s I_s$$

$$\sqrt{3} \times 230 \times I_p = \sqrt{3} \times 115 \times 100$$

$$I_p = 50 \text{ A}$$

Line current star primary leads line current of Δ by 30° .

Hence, the correct option is (A).

Question Number: 54 **Question Type: MCQ**

In the given network $V_1 = 100 \angle 0^\circ$ V, $V_2 = 100 \angle -120^\circ$ V, $V_3 = 100 \angle +120^\circ$ V. The phasor current i (in Ampere) is:

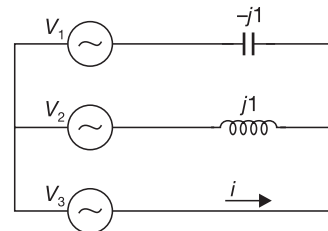

- (A) $173.2 \angle -60^\circ$
- (B) $173.2 \angle 120^\circ$
- (C) $100.0 \angle -60^\circ$
- (D) $100.0 \angle 120^\circ$

Solution: Applying KCL: $i + \frac{V_3 - V_2}{j1} + \frac{V_3 - V_1}{-j1} = 0$

$$i = \frac{V_2 - V_3}{j1} + \frac{V_1 - V_3}{-j}$$

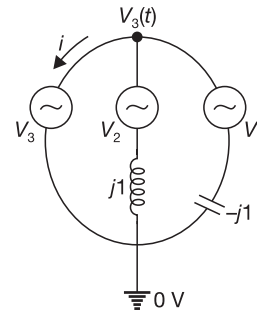

$$i = \frac{(100 \angle -120^\circ) - (100 \angle 120^\circ)}{j1} + \frac{(100 \angle 0^\circ) - (100 \angle 120^\circ)}{-j1}$$

$$i = 173.2 \angle 120^\circ$$

Hence, the correct option is (B).

Question Number: 55 **Question Type: NAT**

A symmetrical square wave of 50% duty cycle has amplitude of ± 15 V and time period of 0.4π ms. This square wave is applied across a series RLC circuit with

$R = 5\Omega$, $L = 10$ mH, and $C = 4$ μ F. The amplitude of the 5000 rad/s component of the capacitor voltage (in Volt) is _____.

Solution:

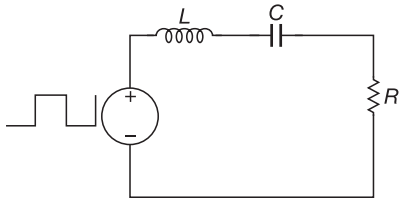

Hence, the correct Answer is (190 to 192 V)

Question Number: 56 **Question Type: NAT**

Two identical coils each having inductance L are placed together on the same core. If an overall inductance of αL is obtained by interconnecting these two coils, the minimum value of α is _____.

Solution:

$$\begin{aligned} \text{Overall inductance} &= Leq = L_1 + L_2 \pm 2M \\ &= L + L \pm 2k\sqrt{LL} \end{aligned}$$

Leq is minimum value when $k = 1$ and two coils are opposing.

$$Leq = L + L - 2L = 0$$

Hence, the correct Answer is (0).

Question Number: 57 **Question Type: MCQ**

A three-winding transformer is connected to an AC voltage source as shown in the figure. The number of turns are as follows: $N_1 = 100$, $N_2 = 50$, $N_3 = 50$. If the magnetizing current is neglected, and the currents in two windings are $\bar{I}_2 = 2 \angle 30^\circ$ A and $\bar{I}_3 = 2 \angle 150^\circ$ A, then what is the value of the current in Ampere?

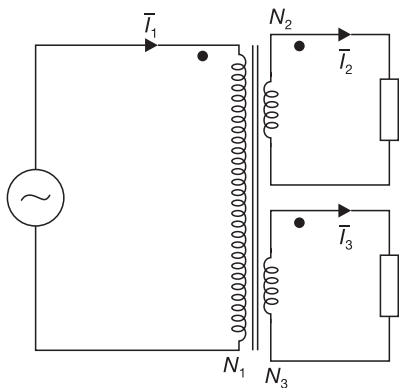

- (A) $1 \angle 90^\circ$ (B) $1 \angle 270^\circ$
 (C) $4 \angle 90^\circ$ (D) $4 \angle 270^\circ$

Solution: Primary current

$$= \bar{I}_1 = \bar{I}_2 + \bar{I}_3$$

$$\bar{I}_1 = 2 \times \frac{50}{100} \angle 30^\circ + 2 \times \frac{50}{100} \angle 150^\circ$$

$$\bar{I}_1 = 1 \angle 30^\circ + 1 \angle 150^\circ = 1 \angle 90^\circ$$

Hence, the correct option is (A).

Question Number: 58 **Question Type: NAT**

With an armature voltage of 100 V and rated field winding voltage, the speed of a separately excited DC motor driving a fan is 1000 rpm, and its armature current is 10 A. The armature resistance is 1Ω . The load torque of the fan load is proportional to the square of the rotor speed. Neglecting rotational losses, the value of the armature voltage (in Volt) which will reduce the rotor speed to 500 rpm is _____.

Solution:

Back emf $E_{b1} = V - R \cdot I = 100 - 10 \times 1 = 90$ V

Torque, $T \propto N^2$, hence $I_o \propto N^2$

$$\frac{I_2}{I_1} = \left(\frac{N_2}{N_1} \right)^2$$

$$\Rightarrow I_2 = 10 \left(\frac{500}{1000} \right)^2 = 2.5$$
 A

Back emf $E_b \propto N$

$$\Rightarrow \frac{E_{b2}}{E_{b1}} = \frac{N_2}{N_1}$$

$$\Rightarrow E_{b2} = 90 \times \left(\frac{500}{1000} \right)$$

$$E_{b2} = 45$$
 V

$$V = E_{b2} + I_2 R = 45 + 2.5 \times 1$$

$$= 47.5$$
 V

Hence, the correct Answer is (47.5 V).

Question Number: 59 **Question Type: NAT**

A three-phase, 11 kV, 50 Hz, 2 pole, stars connected, cylindrical rotor synchronous motor is connected to an 11 kV, 50 Hz source, its synchronous reactance is 50Ω per phase, and its stator resistance is negligible. The motor has a constant field excitation. At a particular load torque, its stator current is 100 A at unity power factor. If the load torque is increased so that the stator current is 120 A, then the load angle (in degrees) at this load is _____.

Solution:

Find excitation

$$E_f = V - I_a \times R \frac{11}{\sqrt{3}} \times 10^3 - j(100 \times 50)$$

$$|E_f| = 8082.23 \text{ V}$$

$$(I_a R)^2 = E_f^2 + V^2 - 2E_f V \cos \delta$$

$$(120 \times 50)^2 = (8082.23)^2 + (6350)^2 - 2(8082.23)(6350) \cos \delta$$

$$\delta = -47.270$$

Hence, the correct Answer is $(-48 \text{ to } -46^\circ)$.

Question Number: 60 **Question Type: NAT**

A 220 V, 3-phase, 4-pole, 50 Hz induction motor of wound rotor type is supplied at rated voltage and frequency. The stator resistance, magnetizing reactance, and core loss are negligible. The maximum torque produced by the rotor is 225% of full load torque and it occurs at 15% slip. The actual rotor resistance is $0.03\Omega/\text{phase}$. The value of external resistance (in Ohm) which must be inserted in a rotor phase if the maximum torque is to occur at start is _____.

Solution: Slip compounding to maximum rotor torque,

$$S_m = \frac{r_2}{X_2}$$

$$0.15 = \frac{0.08}{X_2}$$

$$X_2 = 0.2\Omega$$

For $T_{\text{extra}} = T_{e \text{ max}}$

$$\frac{T_{\text{extra}}}{T_{e \text{ max}}} = \frac{2}{\frac{1}{S_m} + S_m} = 1$$

$$S_m = \frac{r_2^1}{X_2} = 1$$

$$r_2^1 = X_2 = 0.2\Omega$$

External resistance

$$= 0.2 - 0.03 = 0.17\Omega$$

Hence, the correct Answer is $(0.16 \text{ to } 0.18)$.

Question Number: 61 **Question Type: NAT**

Two three-phase transformers are realized using single-phase transformers as shown in the figure given on next column.

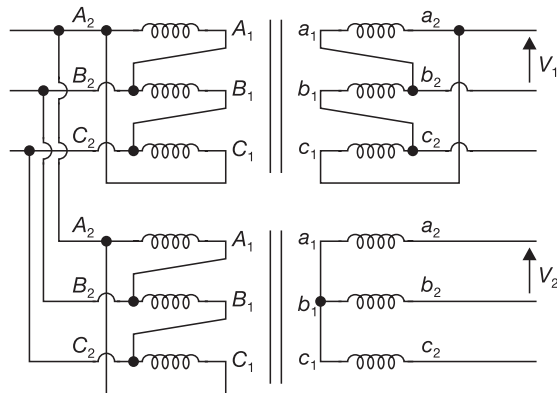

The phase difference (in degree) between voltages V_1 and V_2 is _____.

Solution: The transformer secondaries are connected in Y and Δ hence phase angle difference between them is 30° .

Hence, the correct Answer is (30) .

Question Number: 62 **Question Type: MCQ**

The following discrete-time equations result from the numerical integration of the differential equations of an un-damped simple harmonic oscillator with state variable x and y . The integration time step is h .

$$\frac{x_{k+1} - x_k}{h} = y_x$$

$$\frac{y_{k+1} - y_k}{h} = -x_k$$

For this discrete-time system, which one of the following statements is TRUE?

- (A) The system is not stable for $h > 0$
- (B) The system is stable for $h > \frac{1}{\pi}$
- (C) The system is stable for $0 < h < \frac{1}{2\pi}$
- (D) The system is stable for $\frac{1}{2\pi} < h < \frac{1}{\pi}$

Solution:

Hence, the correct option is (A).

Question Number: 63 **Question Type: MCQ**

The unit step response of a system with the transfer function $G(s) = \frac{1-2s}{1+s}$ is given by which one of the following waveforms?

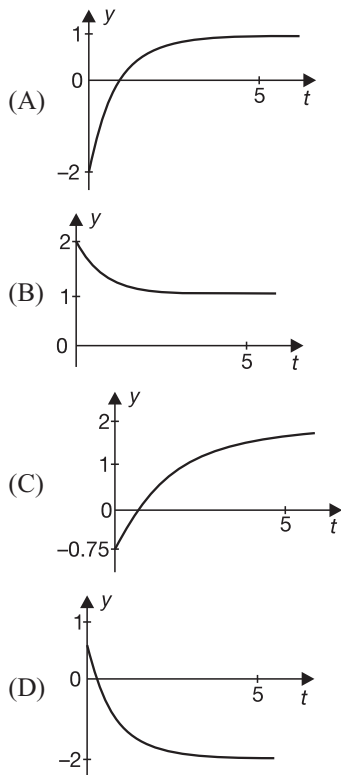

Solution: Transfer function

$$G(s) = \frac{1 - 2S}{1 + S}$$

$$Y(s) = \text{unit step response} = \frac{1}{S} \left(\frac{1 - 2S}{1 + 2S} \right)$$

$$= \frac{1}{S} + \frac{-3}{1 + S}$$

$$y(t) = u(t) - 3e^{-t} u(t)$$

$$y(t) = (1 - 3e^{-t}) u(t)$$

Hence, the correct option is (A).

Question Number: 64 **Question Type: MCQ**

An open loop transfer function $G(s)$ of a system is:

$$G(s) = \frac{K}{s(s+1)(s+2)}$$

For a unity feedback system, the breakaway point of the root loci on the real axis occurs at,

- (A) -0.42
- (B) -1.58

- (C) -0.42 and -1.58
- (D) none of the above

Solution:

Characteristic equation

$$1 + G(s)H(s) = 0$$

$$S(S+1)(S+2) = K = 0$$

$$S[S^2 + 3S + 2] + K = 0$$

$$-K = S^3 + 3S^2 + 2S$$

$$-\frac{dk}{ds} = 3S^2 + 6S + 2 = 0$$

$$S = -0.42 \text{ and } -1.58$$

For $k > 0$, $S = -0.42$

Hence, the correct option is (A).

Question Number: 65 **Question Type: MCQ**

For the system governed by the set of equations:

$$dx_1/dt = 2x_1 + x_2 + u$$

$$dx_2/dt = -2x_1 + u$$

$$y = 3x_1$$

the transfer function $Y(s)/U(s)$ is given by:

- (A) $3(s+1)/(s^2 - 2s + 2)$
- (B) $3(2s+1)/(s^2 - 2s + 1)$
- (C) $(s+1)/(s^2 - 2s + 1)$
- (D) $3(2s+1)/(s^2 - 2s + 2)$

Solution:

$$\begin{bmatrix} \dot{x}_1 \\ \dot{x}_2 \end{bmatrix} = \begin{bmatrix} 2 & 1 \\ -2 & 0 \end{bmatrix} \begin{bmatrix} x_1 \\ x_2 \end{bmatrix} + \begin{bmatrix} 1 \\ 1 \end{bmatrix} [4]$$

$$[4] = [3 \ 0] \begin{bmatrix} x_1 \\ x_2 \end{bmatrix}$$

Transfer function

$$\frac{Y(s)}{U(s)} = C[SI - A]^{-1} B$$

$$= [3 \ 0] \left\{ \begin{bmatrix} S & 0 \\ 0 & S \end{bmatrix} - \begin{bmatrix} 2 & 1 \\ -2 & 0 \end{bmatrix} \right\}^{-1} \begin{bmatrix} 1 \\ 1 \end{bmatrix}$$

$$= [3 \ 0] \begin{bmatrix} S & 1 \\ -2 & S-2 \end{bmatrix} \begin{bmatrix} 1 \\ 1 \end{bmatrix}$$

$$= \frac{3(S+1)}{S^2 - 2S + 1}$$

Hence, the correct option is (A).